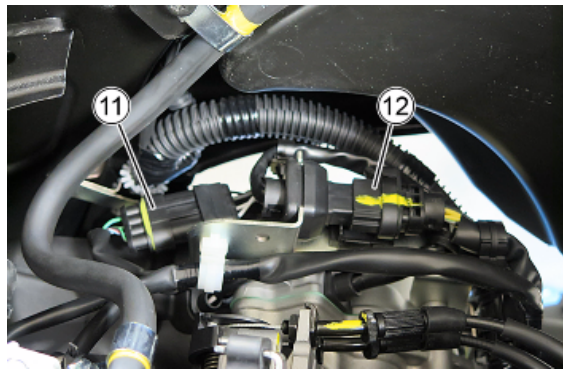
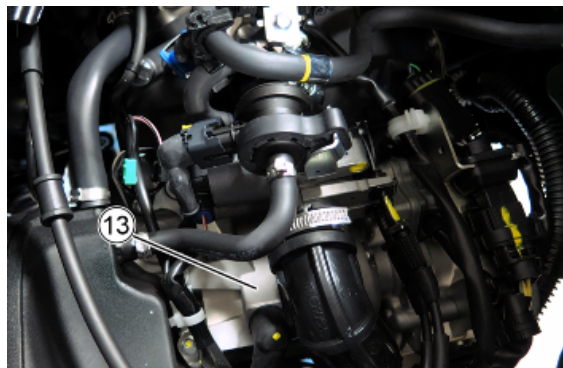

**11. LAMBDA PROBE CONNECTOR****12. FLYWHEEL CONNECTOR**

- To reach it, remove the helmet compartment.

**13. STARTER MOTOR**

- To reach it, remove the helmet compartment.

**14. LICENCE PLATE LIGHT**

- Remove the licence plate light cover to reach it.

**15. REAR RIGHT TURN INDICATOR**

---

**16. REAR LIGHT**

- Remove the rear headlight assembly to reach it.

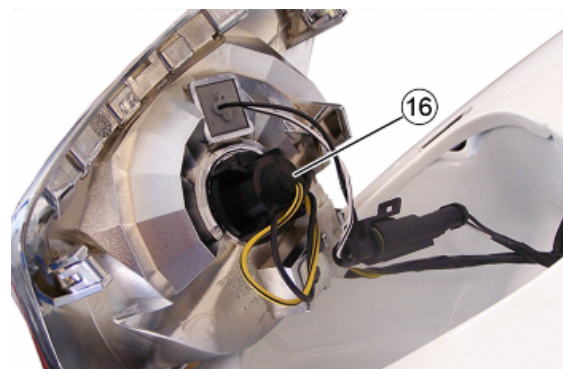

---

**17. IGNITION SWITCH**

**18. IMMOBILIZER ANTENNA**

- Remove the leg shield back plate to reach it.

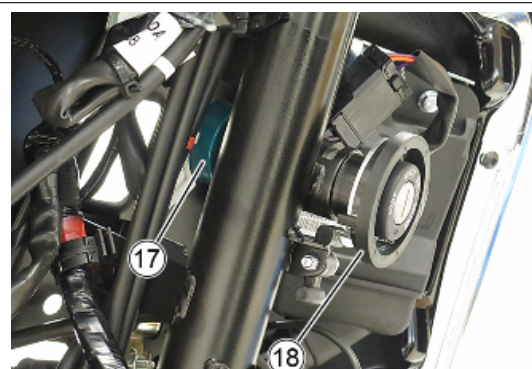

---

**19. INSTRUMENT CLUSTER**

- Remove the upper handlebar cover to reach it.

---

**FOR THE VERSION WITH ANALOGUE INSTRUMENT PANEL**



---

**FOR "S" VERSION**



**20. LEFT HAND STOP SWITCH**

- Remove the upper handlebar cover to reach it.

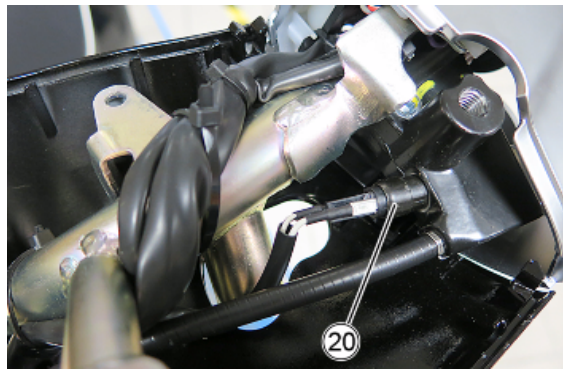
**21. HORN SWITCH****22. TURN INDICATOR SWITCH****23. HIGH/LOW BEAM LIGHTS SWITCH**

- Remove the upper handlebar cover to reach it.

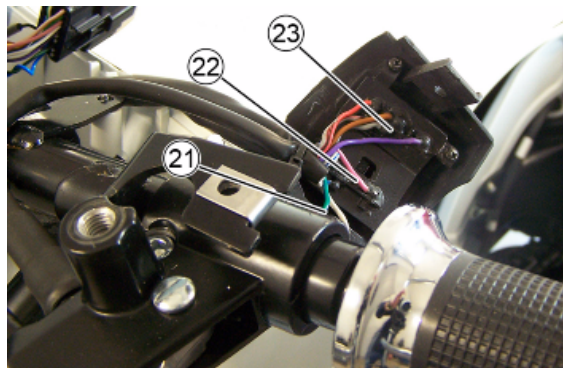
**24. HV COIL.**

- To reach it, remove the helmet compartment.

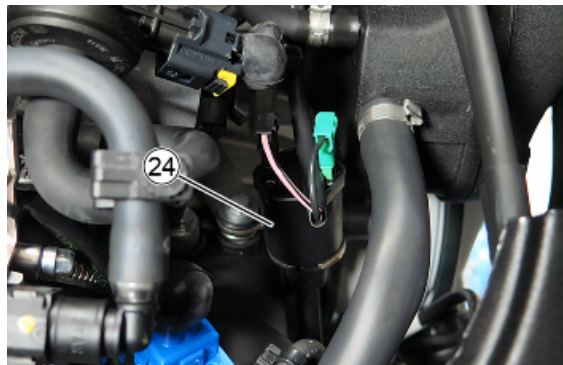
**25. THROTTLE POSITION SENSOR**

- To reach it, remove the helmet compartment

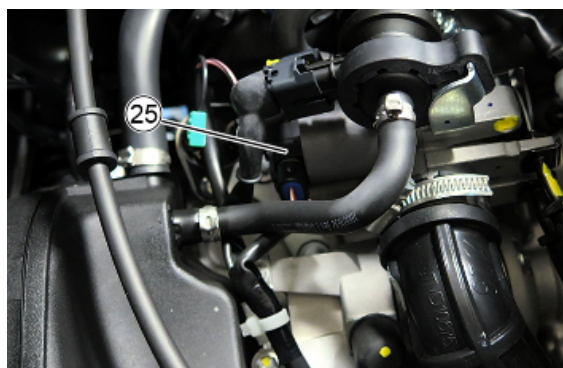

**26. IDLE SPEED ADJUSTMENT DEVICE**

- To reach it, remove the helmet compartment.

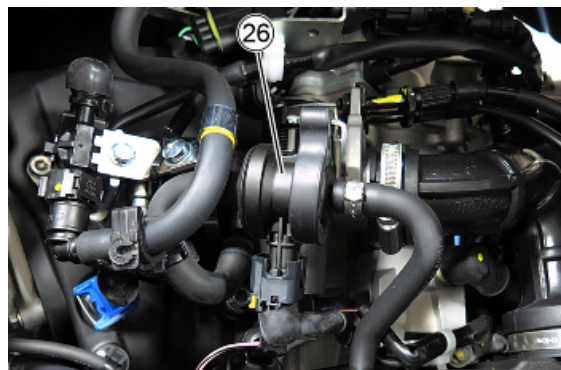

**27. REAR LEFT TURN INDICATOR**



**28. ENGINE TEMPERATURE SENSOR**

- To reach it, remove the helmet compartment.



**29. INJECTOR**

- To reach it, remove the helmet compartment.

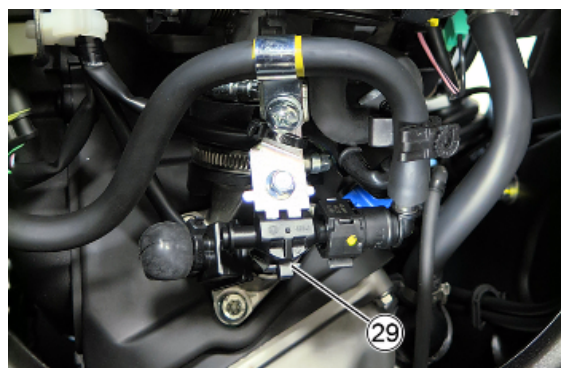

**31. USB PORT CONNECTOR**

- Located in the case, remove the leg shield back plate to access it.

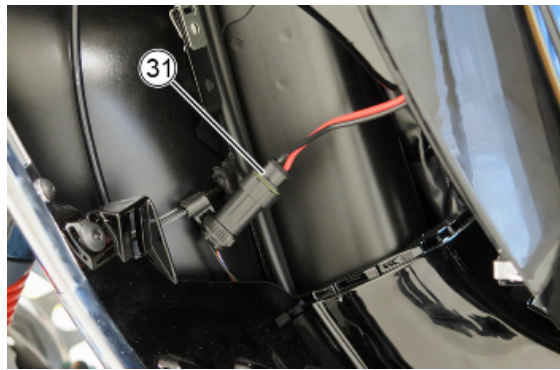
**32. FRONT LEFT TURN INDICATOR**

- Remove the leg shield back plate to reach it.

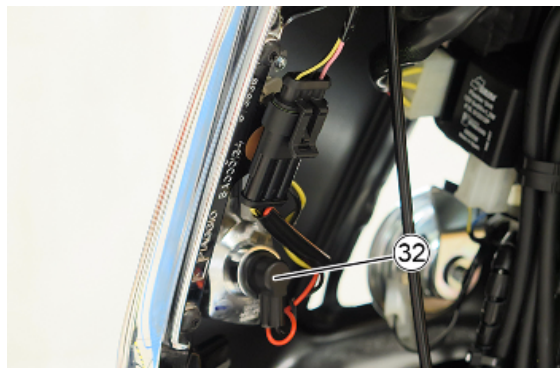
**33. TURN INDICATORS INTERMITTENCE**

- Remove the leg shield back plate to reach it.

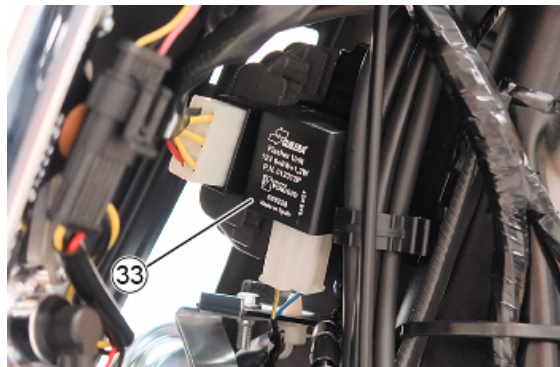
**34. ABS TONE WHEEL SENSOR CONNECTOR**

- Remove the case to reach the connector.

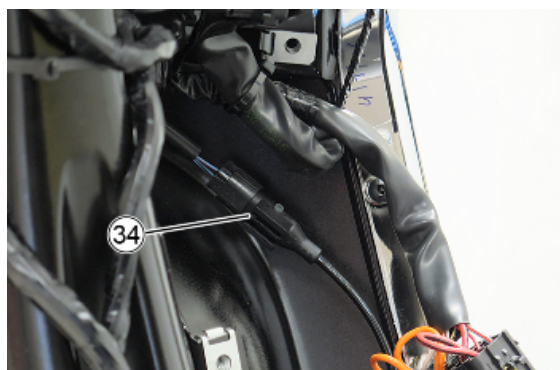

**35. HORN**

**36. VOLTAGE REGULATOR**

- Remove the steering cover to reach it.

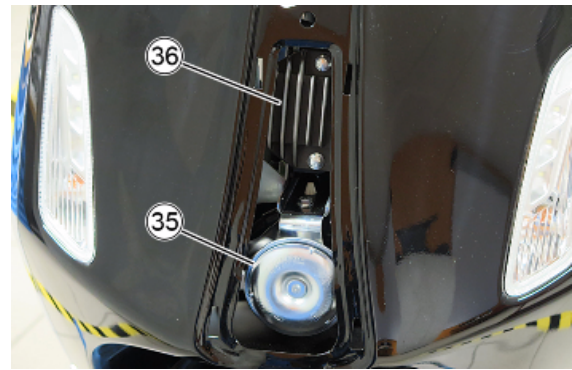

**37. INJECTION ECU**

- Remove the leg shield back plate to reach it.

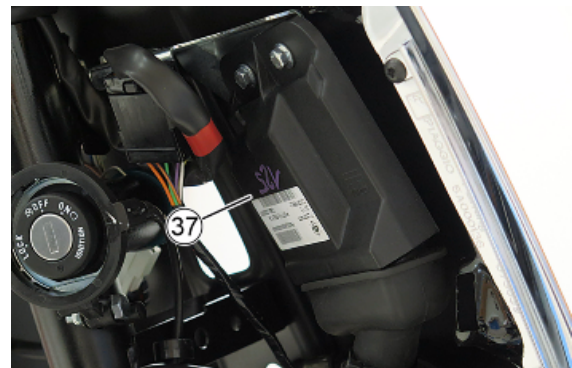

**38. DIAGNOSTIC SOCKET (DIGITAL DISPLAY)  
PAP VERSION**

- Remove the steering cover to reach it.

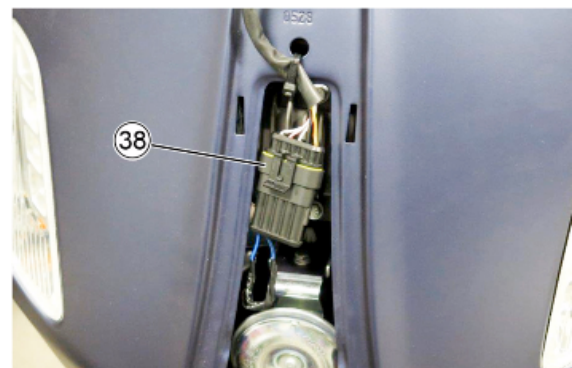

**39. AMBIENT TEMPERATURE SENSOR FOR  
"S" VERSION**

- Remove the leg shield back plate to reach it.

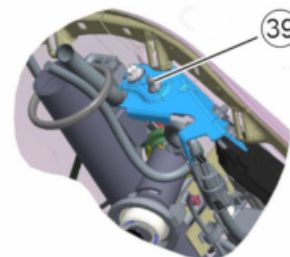

**Instrument panel**

**A** = Speedometer

**B** = Immobilizer LED

**C** = MIL - Injection system failure warning light

**D** = Turn indicator warning light

**E** = Low fuel warning light

F = Digital display

G = Low engine oil pressure warning light

H = High-beam warning light

I = ABS warning light

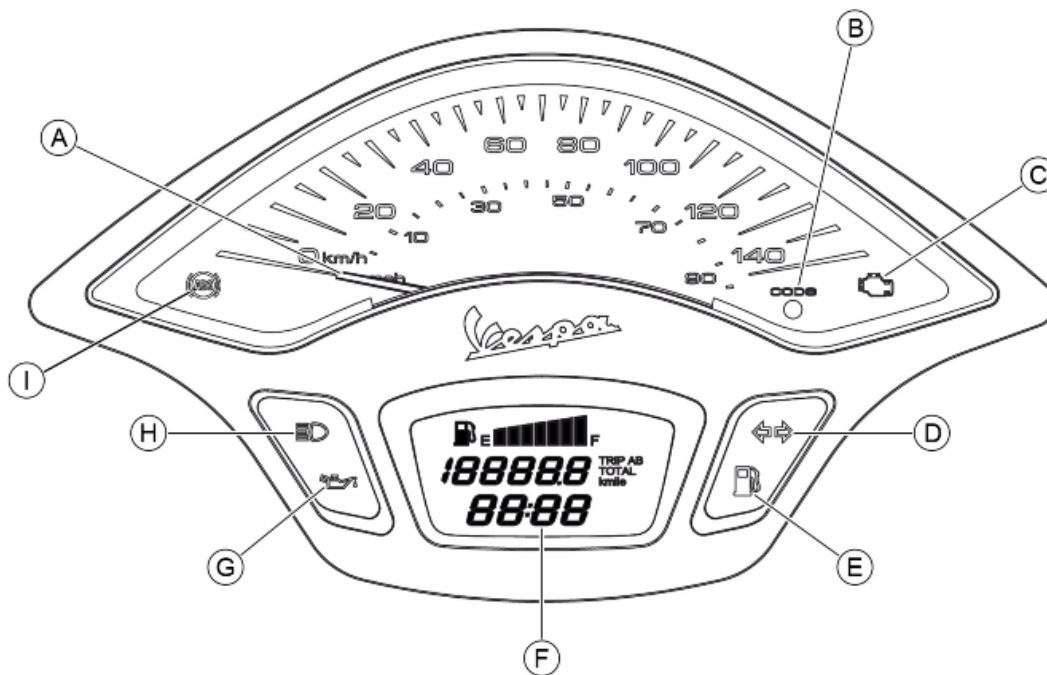

G = Fuel gauge with petrol symbol

H = Total or partial odometer

I = Clock

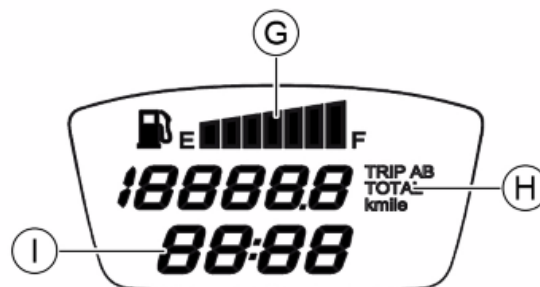

By turning the ignition key to the «ON» position all the digital display functions will light up for a few seconds.

#### TOTAL OR PARTIAL ODOMETER "H"

Acting on the MODE button this indicator displays the following functions in sequence:

- Total odometer (TOTAL)
- Partial odometer A (TRIP A)
- Partial odometer B (TRIP B)

It is possible to change the unit of measure (from km to miles) following the procedure below:

- move the key to «OFF»;
- press the MODE key;
- Holding in the MODE button, turn the key to the «ON» position;
- after about 2 seconds release the MODE button.

**N.B.****THE FOLLOWING ARE DEFINED WHEN NAVIGATING THE DISPLAY:**

- «BRIEF PRESS»: A PRESS OF THE INDICATED BUTTON, FOR A PERIOD OF LESS THAN TWO SECONDS;
- «PROLONGED PRESS»: A PRESS OF THE INDICATED BUTTON, FOR A PERIOD OF MORE THAN TWO SECONDS.

To set or adjust the clock, with vehicle running or with key inserted in «ON» position, proceed as follows:

- short press the MODE button in sequence until the odometer appears on the display;
- press and hold it to enter the hour display;
- adjust the hour by short pressing the MODE button;
- with a long press, the set value is confirmed (or present value if not modified) and it goes on to the minutes display
- adjust the minutes by short pressing the MODE button;
- by pressing and holding, the set value (or the current value if not modified) is confirmed and the set or modified hour is displayed.

**WARNING**

**FOR SAFETY REASONS THE TIME SETTING IS ONLY POSSIBLE WITH THE VEHICLE AT A STANDSTILL.**

**WARNING**

**DISCONNECTING THE BATTERY CABLES WILL RESULT IN A RESET OF THE CLOCK WHICH WILL INDICATE "12:00" UNTIL NEW SETTING.**

**FOR "S" VERSION****ANALOGUE INSTRUMENT CLUSTER**

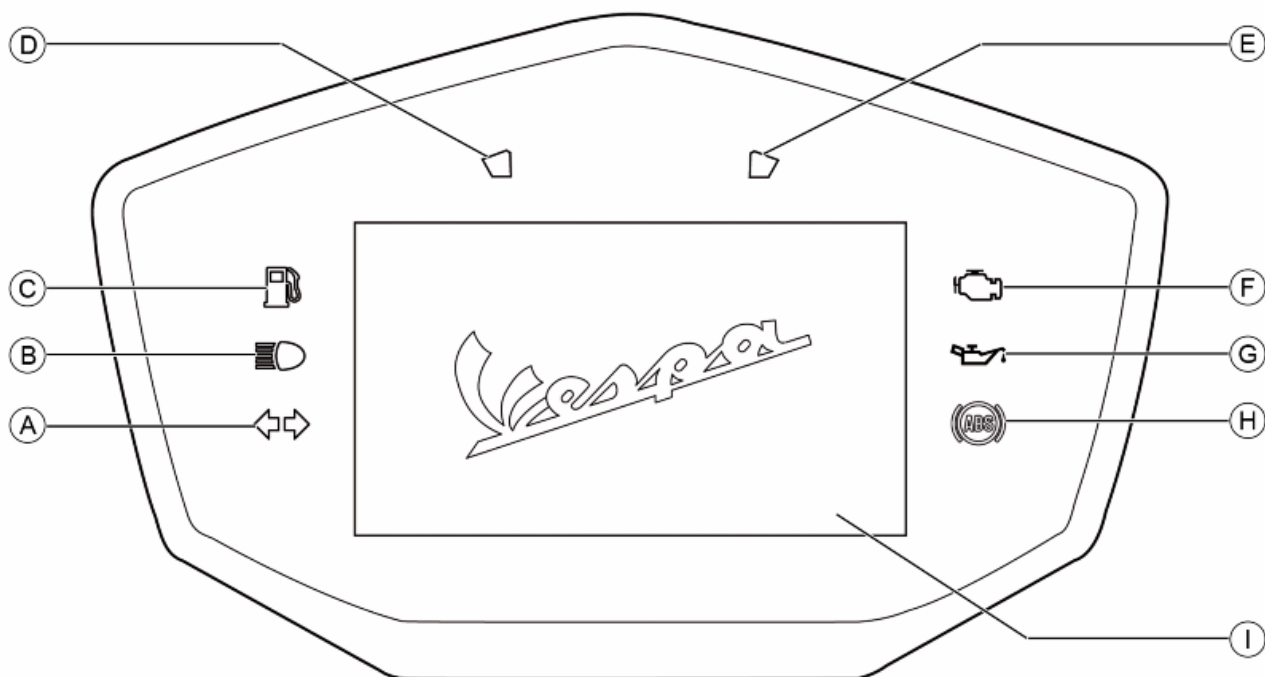

**Indicator and warning lamps:**

**A** = Turn signal indicator light;

**B** = High-beam warning light

**C** = Fuel reserve warning light

**D** = Immobilizer LED

**E** = Digital display light sensor

**F** = Engine control tell-tale light

**G** = Low engine oil pressure warning light

**H** = ABS warning light

**I** = Digital display

**DIGITAL DISPLAY**

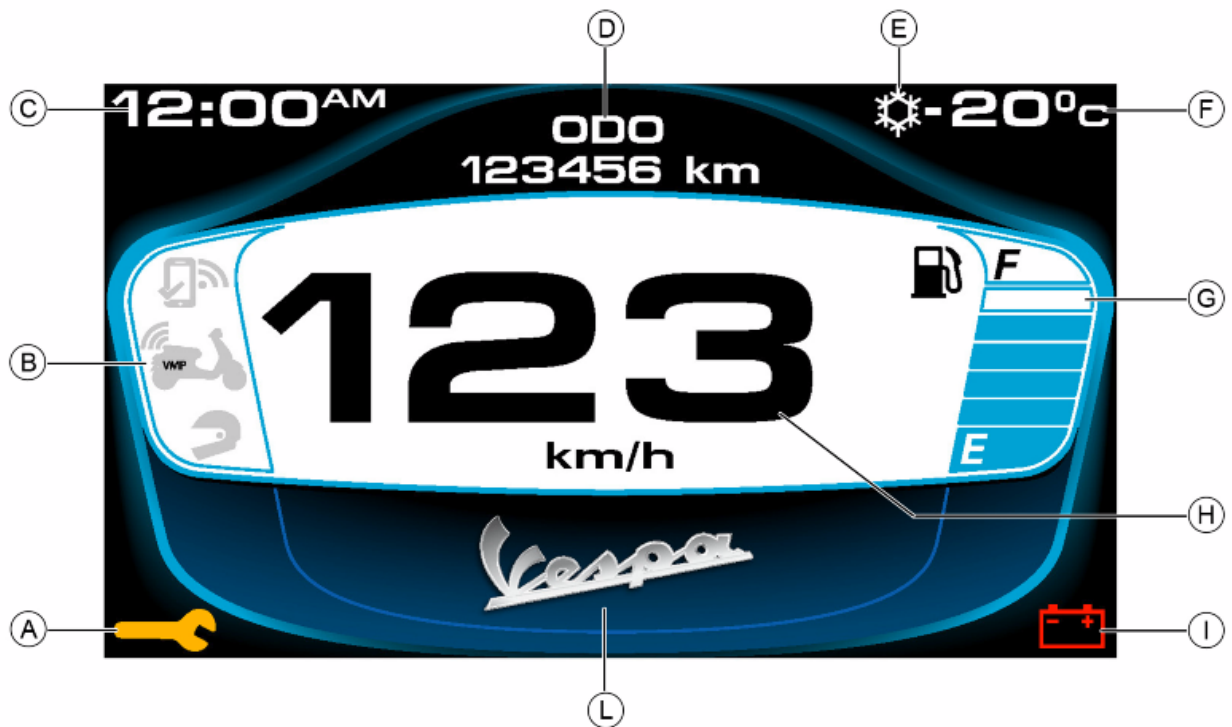
**Key:**

**A** = Service icon

**B** = VMP (Vespa Multimedia Platform) icon panel

**C** = Clock

**D** = Multifunctional panel

**E** = Ice hazard icon

**F** = Ambient temperature indicator

**G** = Fuel gauge

**H** = Tachometer

**I** = Battery state of charge icon

**L** = Graphic panel and infotainment

By turning the ignition switch to "**ON**" position and then to "**OFF**" position, the digital display will show a "Welcome" and "Good bye".

**Service icon (A)**

At vehicle ignition, immediately after the ignition check, if there are less than 300 km to the next scheduled service, the corresponding icon flashes for 5 seconds. Once the service mileage has been reached, the icon remains steadily on until the service operations are performed.

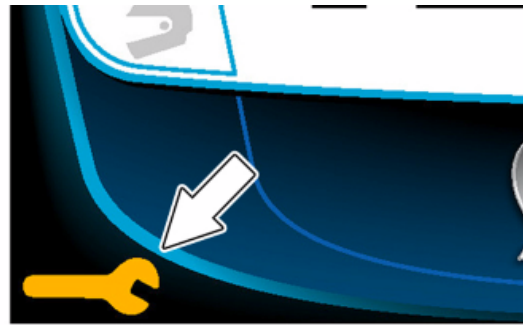
**VMP (Vespa Multimedia Platform) icon panel****(B)**

**A** = Bluetooth connection with smartphone device icon.

**B** = VMP (Vespa Multimedia Platform) application icon.

**C** = Audio transmission between smartphone and Bluetooth headset icon.

The icons listed above are displayed in green when the respective function or status is active.

**Ice hazard icon (E)**

At ambient temperatures below 3°C, the ice hazard icon is shown on the digital display to warn the rider of the possibility of ice on the road. In such conditions, it is recommended to drive carefully.

**Battery state of charge icon (I)**

When the value of the battery voltage is close to the minimum operating value, the display will indicate the above specified anomaly by switching on the relevant icon. In these conditions, it is recommended to recharge or replace the battery, if necessary.



**Multifunctional panel (D)**

The **MODE** selector is used to navigate through the functions of the multifunctional panel.

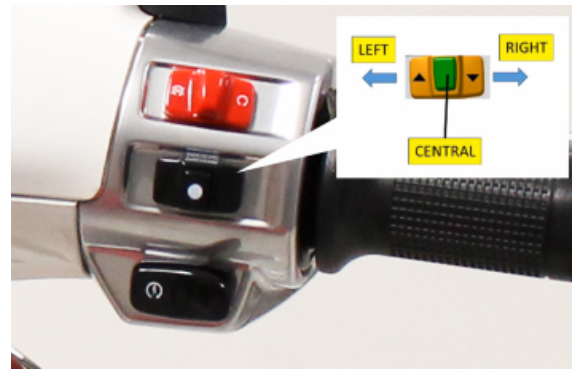

Briefly press the **MODE** button on the handlebar **to the RIGHT** repeatedly to view the following functions cyclically:

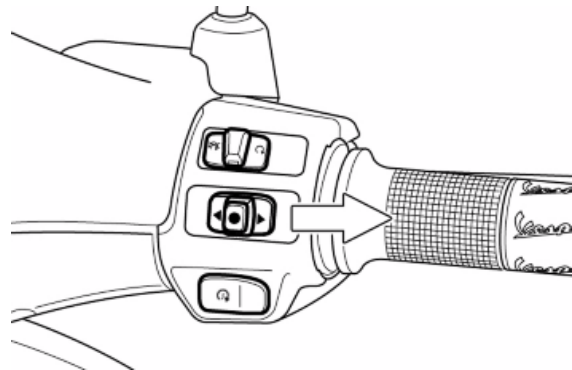

**A** = ODO (total odometer)

**B** = TRIP A (partial odometer A)

**C** = TRIP TIME A (trip time on odometer A) - the trip time is only counted at vehicle speeds above 5 Km/h

**D** = TRIP B (partial odometer B)

**E** = TRIP TIME B (trip time on odometer B) - the trip time is only counted at vehicle speeds above 5 Km/h

**F** = MAX SPEED (maximum speed on odometer A) - for speeds above mph (5 Km/h)

**G** = AVG SPEED (average speed on odometer A)

**H** = BATTERY (voltmeter)

**I** = SETTING

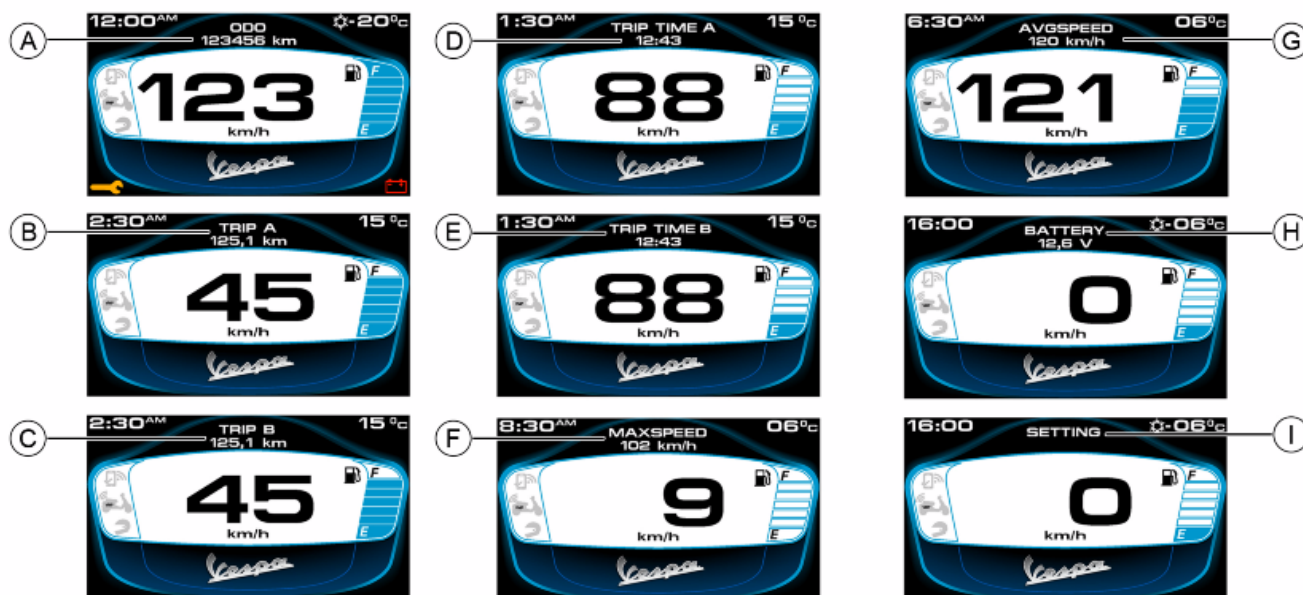

By pushing the **MODE selector to the RIGHT** and holding it, the partial values of the following functions can be reset (while the function is displayed):

**For TRIP A** (partial odometer A), the following are automatically reset:

- TRIP A (partial odometer A);
- TRIP TIME A (trip time on odometer A);
- MAX SPEED (maximum speed on odometer A);
- AVG SPEED (average speed on odometer A).

**For TRIP B** (partial odometer B), the following are automatically reset:

- TRIP B (partial odometer B);
- TRIP TIME B (trip time on odometer B).

N.B.



**"PRESS BRIEFLY AND RELEASE":** PRESS THE BUTTON AND RELEASE WITHIN 0.5 SECONDS;  
**"PRESS AND HOLD":** PRESS THE BUTTON AND HOLD FOR AT LEAST 2 SECONDS.

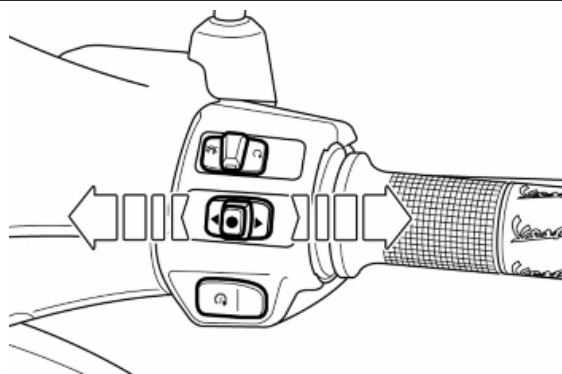

**SETTINGS function**

By briefly pressing the **MODE** button on the handlebar **to the RIGHT**, scroll the functions on the multifunctional panel until the "SETTINGS" function is displayed.

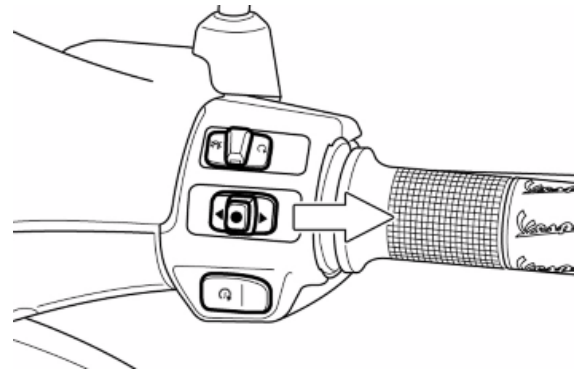

This function allows accessing and, if necessary, changing the viewing settings of the display.

**CAUTION**  
**WARNING**



**THE SETTINGS FUNCTION IS ONLY ACCESSIBLE WITH THE VEHICLE AT A STANDSTILL.**



Once the "SETTINGS" function is displayed, **press and hold the MODE selector to the RIGHT** to access the sub-menus and modify the settings, if necessary.

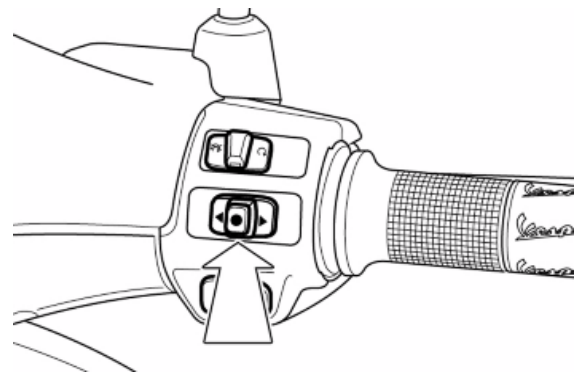

The displayed sub-menus are the following:

- Language
- Configuration
- Backlight
- Graphics
- Exit

By briefly pressing the **MODE** button **to the RIGHT** or **to the LEFT**, the various sub-menus of the "SETTINGS" function can be scrolled.

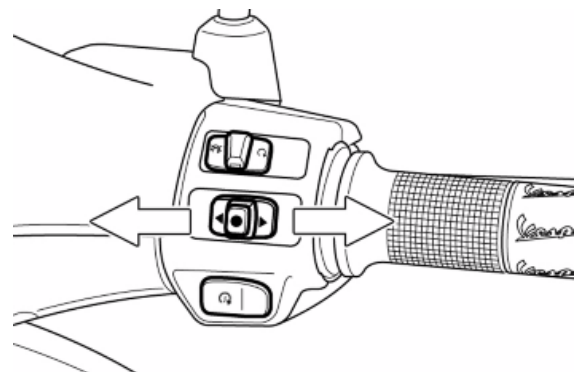

Once the required submenu is selected, it is highlighted in green; now press and the **CENTRE** of the **MODE** selector briefly to select the required parameter:

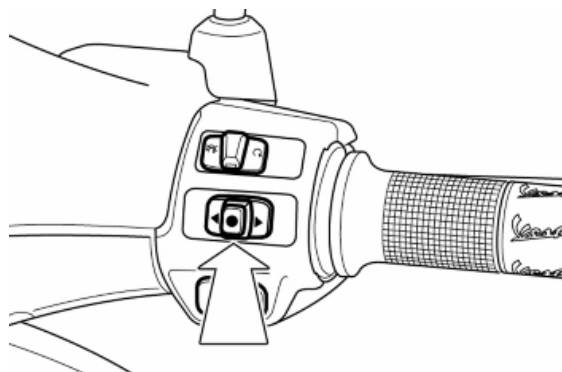

### 1. "Language" submenu

- Italian: ON-OFF
- English: ON-OFF
- French: ON-OFF
- German: ON-OFF
- Spanish: ON-OFF
- Exit

### 2. "Configuration" menu

- Clock: Set time; 12h, 24h / ON, OFF / Exit
- Units of measurement:
- Speed: Km/h, Mph / ON, OFF / Exit Temperature: °C: ON-OFF / °F: ON-OFF / Exit
- Pairing configuration: Pairing
- Exit

### 3. "Backlight" menu

- Set: Day mode: Numeric value to set / Night: Numeric value to set / Exit
- Automatic: ON-OFF
- Day mode: ON-OFF
- Night mode: ON-OFF
- Exit

### 4. "Graphics" menu

- Vespa: ON-OFF
- Vision: ON-OFF
- Pixel: ON-OFF
- Exit

By briefly pressing the **MODE** button **to the RIGHT** or **to the LEFT**, the various sub-menus can be scrolled.

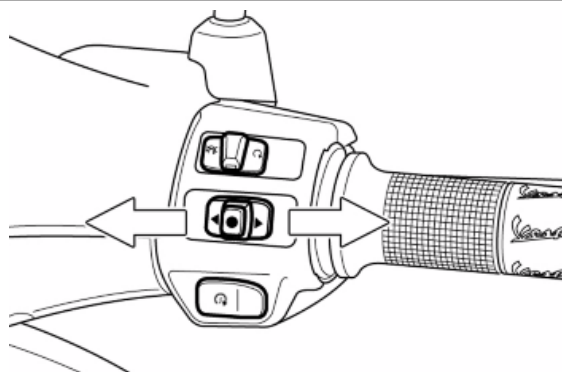

Once the required submenu is selected, it is highlighted in green; then, by briefly pressing the **CENTRAL** part of the **MODE** button, the parameters related to the menu in question can be accessed.

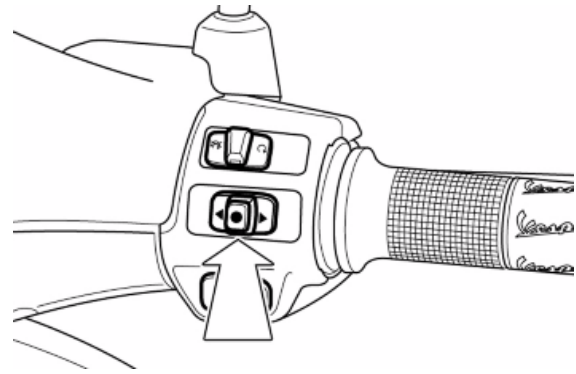

### Units of measurement.

With "**SETTINGS**" mode highlighted on the digital display, press and hold the MODE selector to the right to access the following menu options:

#### CONFIGURATION

- Clock
- Units of measurement: speed, temperature, exit
- Pairing configuration
- Exit



Press the **CENTRE** button of the mode selector briefly to select the parameter:

**Speed:** select the required unit of measurement, choosing from the following options: **Km/h, mph / ON, OFF.**

**Temperature:** select the required unit of measurement, choosing from the following options: **degrees°C, °F / ON, OFF.**

### Clock

With "**SETTINGS**" mode highlighted on the digital display, press and hold the MODE selector to the right to access the following menu options:

#### CONFIGURATION

- Clock: set time, 12h / 24h
- Unit of measurement
- Pairing configuration
- Exit



Press the **MODE** selector repeatedly to the right or left to scroll to the required setting and press the



CENTRE button of the mode selector briefly to select the setting:

- Set time (hours, minutes, exit)
- 12h
- 24h
- Exit

### INFOTAINMENT SYSTEM - VMP (Vespa Multimedia Platform)

The vehicle is equipped with a VMP (Vespa Multimedia Platform) unit which communicates via Bluetooth with the user's smartphone to allow infotainment functions and to permit data transfer with the vehicle via a specific app installed on the smartphone itself.

Once a connection is established correctly between the VMP unit and the smartphone, the following functions are accessible and controllable directly from the digital display of the vehicle:

- manage phone calls;
- manage audio playback;
- SMS notifications management.



### Pairing configuration

Turn the ignition switch to activate the digital display.

With **"SETTINGS"** mode highlighted on the digital display, press and hold the MODE selector to the right to access the following menu options:

#### CONFIGURATION

- Clock (set time, 12h, 24h)
- Unit of measurement
- Pairing configuration (pairing)
- Exit

From the **"Pairing configuration"** menu, **press the centre button of the MODE selector** and **press again on "Pairing"**. The message **"Pairing enabled"** is shown on the vehicle display, and the



device "BT-ROUTER" appears on the smartphone.

Enable the bluetooth function on the smartphone and select device search.

**PAIRING SMARTPHONE:** select BT-ROUTER and then enter the code: 0000; press "pair". The message "Pairing completed" is shown on the vehicle display.

**PAIRING procedure for Bluetooth HEADSET:** search the "Vespa" App in Play Store or App Store, and install the application; sign up by following the instructions; select "allow" for the position and notifications management requests. Start the App, set the headset to "Pairing" mode, following the smartphone instructions and after the smartphone displays the headset, press "pair". At this point, all the functions of the App can be used: music playback and phone calls; they will be viewed with various messages on the digital display of the vehicle.

As soon as the Bluetooth connection with the smartphone is established, the relative icon on the display appears in green.

**Allow sharing the phone book and notifications when and if this is requested. These permissions are required to view the name of the caller and the SMS receipt notification on the display.**

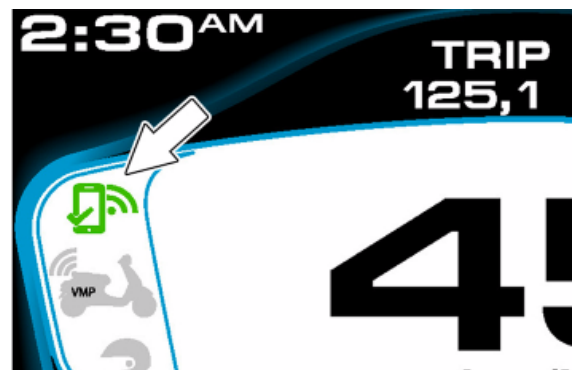

In the above mentioned condition, by activating the previously installed "Vespa" App on the smartphone and after having selected the vehicle model, the vehicle and trip information will be available; the relative icon on the display will light up green.



Otherwise, the following information is shown on the display:

- VMP fault, proceed with the display diagnostic.



- Connection with smartphone NOT active.

N.B.



ALL INPUT VIA THE MODE SELECTOR IS IGNORED WHEN A POPUP WINDOW IS ACTIVE ON THE DISPLAY. THE POPUP WINDOW MUST BE CLEARED FROM THE DISPLAY TO RESTORE NORMAL OPERATION OF THE MODE SELECTOR.

N.B.

THE FOLLOWING ARE DEFINED WHEN NAVIGATING THE DISPLAY:

- «BRIEF PRESS»: PRESSING THE BUTTON INDICATED FOR LESS THAN HALF A SECOND;
- «PROLONGED PRESS»: PRESSING THE BUTTON INDICATED FOR MORE THAN THREE SECONDS.

### MANAGING CALLS AND RECEIVING SMS TEXT MESSAGES

In order to display notifications and identification of incoming calls on the vehicle display, the display options to share notifications and contacts must be enabled in the BT-ROUTER device options, in the smartphone's Bluetooth menu.

Please note that on iOS systems the message notifications will be displayed ONLY at the second connection of the smartphone to the vehicle.

N.B.



**WHEN A SMARTPHONE CONNECTS WITH THE VMP SYSTEM (BT-ROUTER), AUDIO IS AUTOMATICALLY ROUTED TO THE VMP SYSTEM.**

**IF NO HEADSET IS CURRENTLY CONNECTED TO THE VMP SYSTEM, THE USER WILL NOT BE ABLE TO HEAR VOICE CALLS OR LISTEN TO AUDIO PLAYBACK.**

**IF NO HEADSET IS CONNECTED TO THE VMP SYSTEM, THE AUDIO INPUT AND OUTPUT SETTINGS OF THE SMARTPHONE MUST BE CHANGED MANUALLY TO ROUTE AUDIO TO/FROM THE REQUIRED DEVICES (E.G. SPEAKER AND MICROPHONE OF SMARTPHONE).**

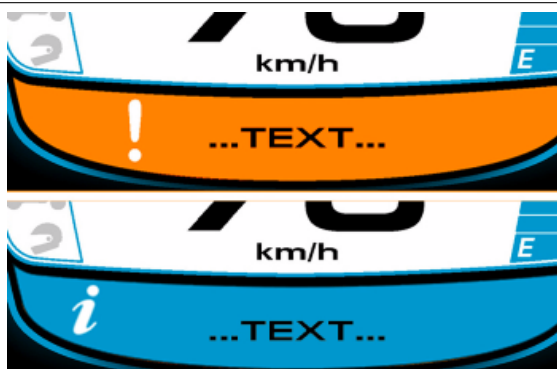



**Key:**

- A = Incoming call
- B = Call ended or rejected
- C = SMS message received
- D = Vocal control in use

A headset device must be connected to the smart-phone to enable call functions; the relative icon on the display appears in green when the headset is active.



The functions of the **MODE** selector for managing phone calls are as follows:

**MODE SELECTOR FUNCTION FOR MANAGING CALLS**

Specification	Desc./Quantity
Accept incoming call	CENTRAL BUTTON BRIEF PRESS
End an active call	CENTRAL BUTTON LONG PRESS
Reject incoming call	CENTRAL BUTTON LONG PRESS
Cancel outgoing call	CENTRAL BUTTON LONG PRESS
Clear most recent missed call popup (with NO call in progress)	CENTRAL BUTTON BRIEF PRESS
Redial last missed call number (with NO call in progress)	CENTRAL BUTTON LONG PRESS
Increase volume (with call in progress)	PRESS SELECTOR BRIEFLY TO THE RIGHT

Specification	Desc./Quantity
Lower volume (with call in progress)	PRESS SELECTOR BRIEFLY TO THE LEFT
Enable/disable voice command	PRESS SELECTOR TO THE LEFT AND HOLD

**MANAGING AUDIO PLAYBACK**

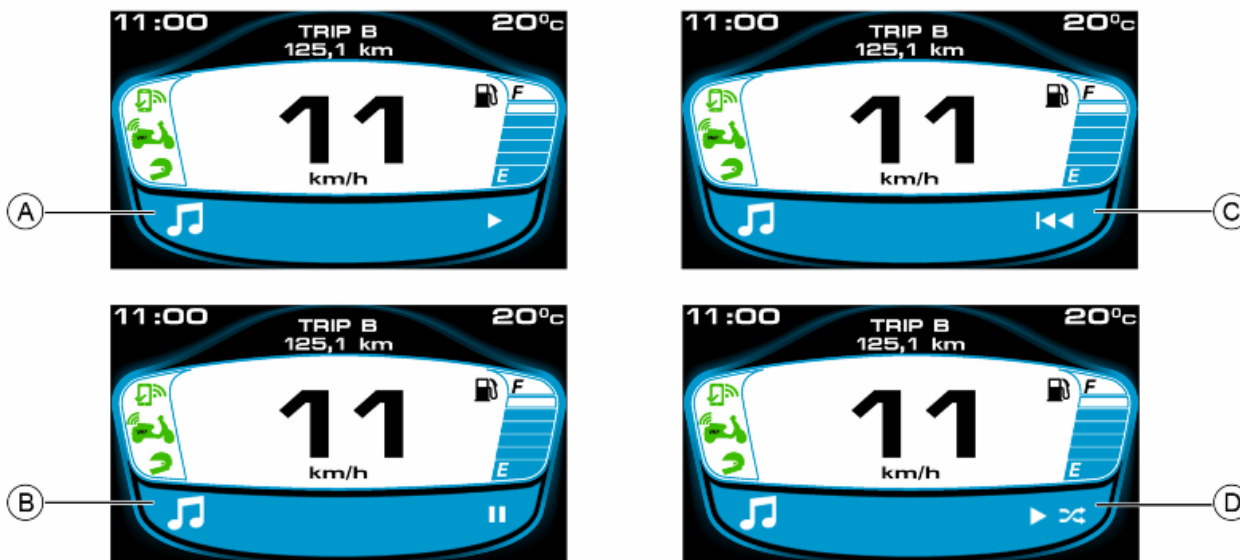

**Key:**

- A = Audio playback in progress
- B = Current track paused
- C = Scan track forwards
- D = Random music playback

A headset device must be connected to the smart-phone in order to listen to audio; the relative icon on the display appears in green when the headset is active.



The functions of the **MODE** selector for managing audio playback are as follows:

**MODE SELECTOR FUNCTION FOR MANAGING AUDIO PLAYBACK**

Specification	Desc./Quantity
Play track	CENTRAL BUTTON BRIEF PRESS
Increase audio volume (with audio playback in progress)	PRESS SELECTOR BRIEFLY TO THE RIGHT

Specification	Desc./Quantity
Lower audio volume (with audio playback in progress)	PRESS SELECTOR BRIEFLY TO THE LEFT
Next audio track	PRESS SELECTOR TO THE RIGHT AND HOLD
Previous audio track	PRESS SELECTOR TO THE LEFT AND HOLD
Play music/ pause / random music	CENTRAL BUTTON BRIEF PRESS
Exit audio playback mode	CENTRAL BUTTON BRIEF PRESS

## Ground points

On the vehicle there is a ground point on the chassis marked with the letter "A", remove the footrest to access it.

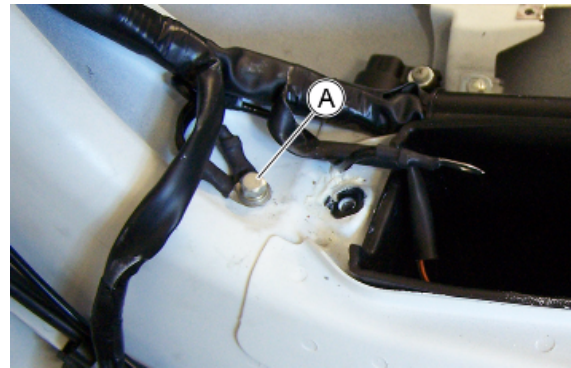

On the engine is a ground point "B" on the starter motor.

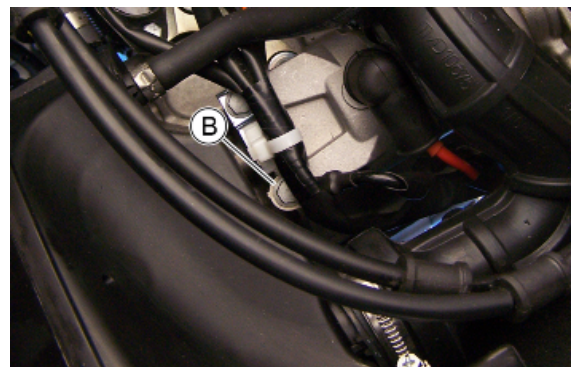

On the left side of the chassis, under the footrest, the chassis - engine ground cable "C" is fixed.



## Electrical system installation

## Front side

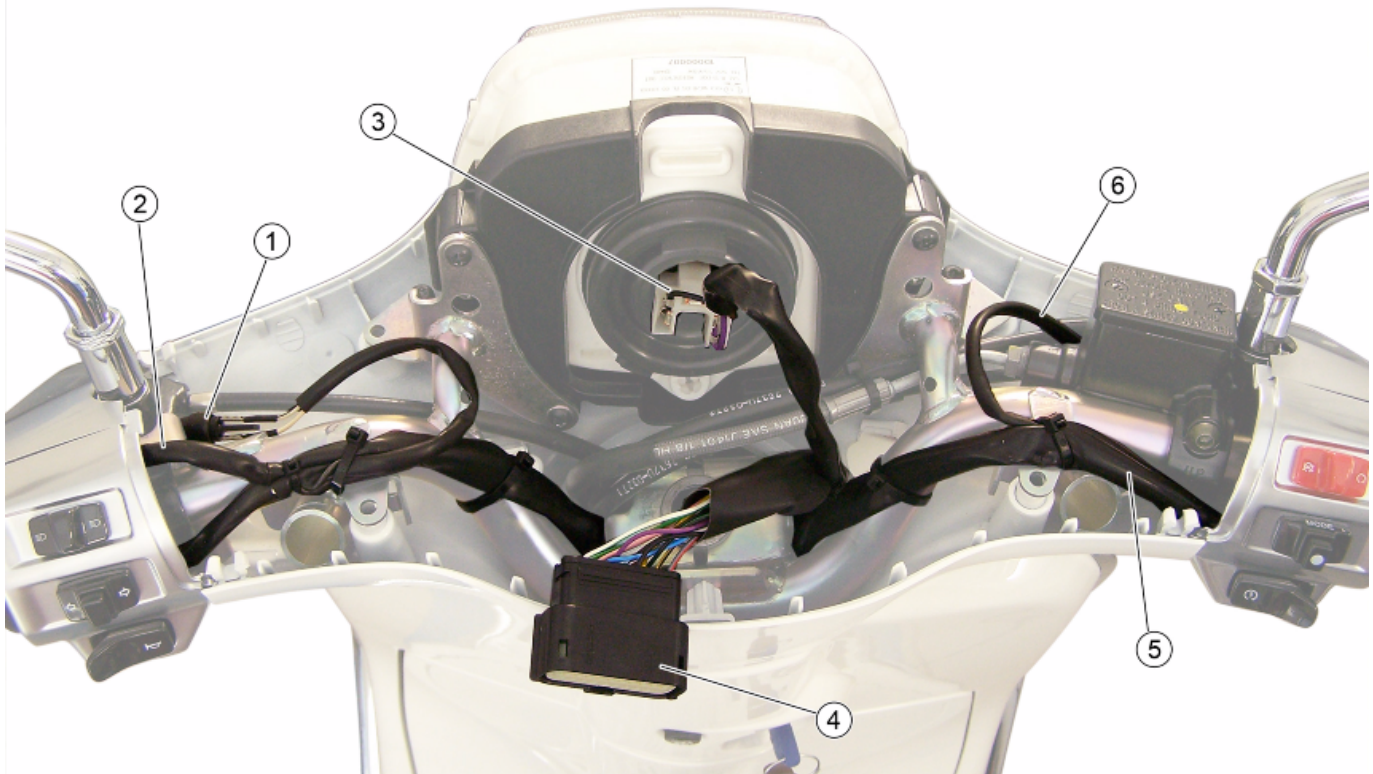

1. Left stop button
2. Left control lock
3. Headlight connector
4. Instrument panel connector
5. Right control lock
6. Right stop button

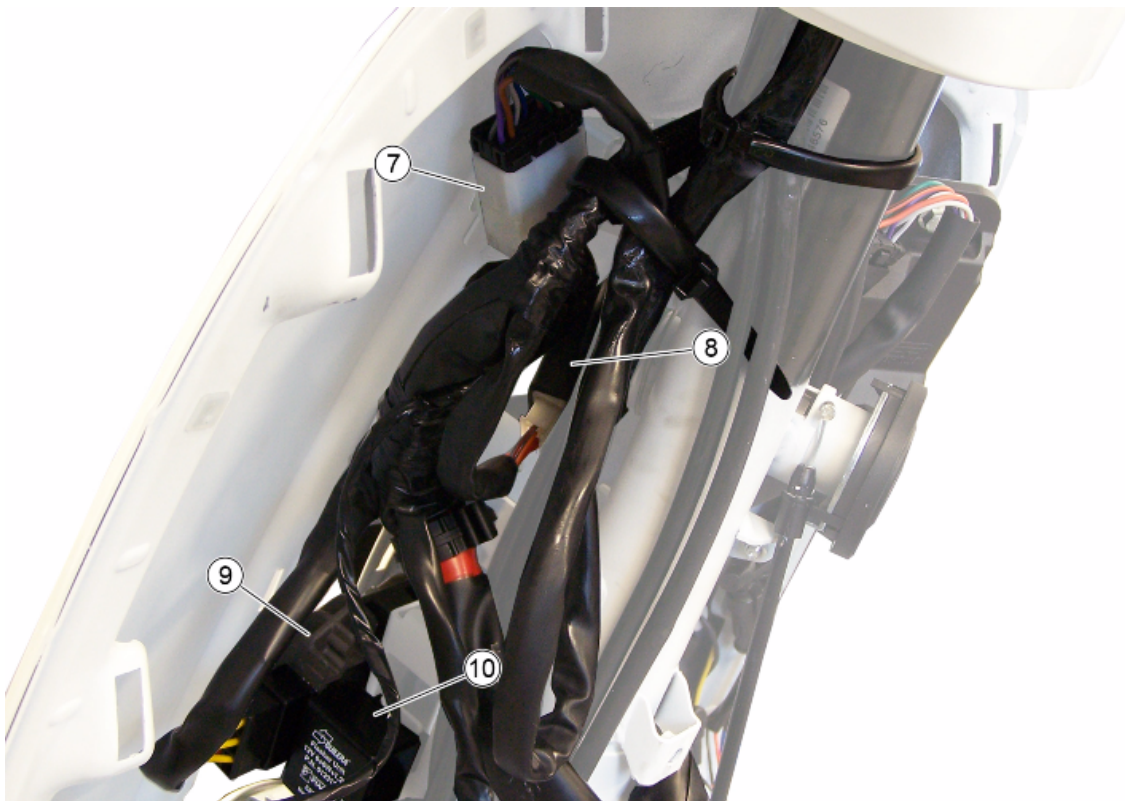

7. Left electrical controls connector

8. Ignition switch

9. Voltage regulator

10. Turn indicator control device





- 11. Voltage regulator connector
- 12. Front left turn indicator connector
- 13. Horn connections
- 14. Saddle opening switch connector
- 15. To speed sensor on wheel

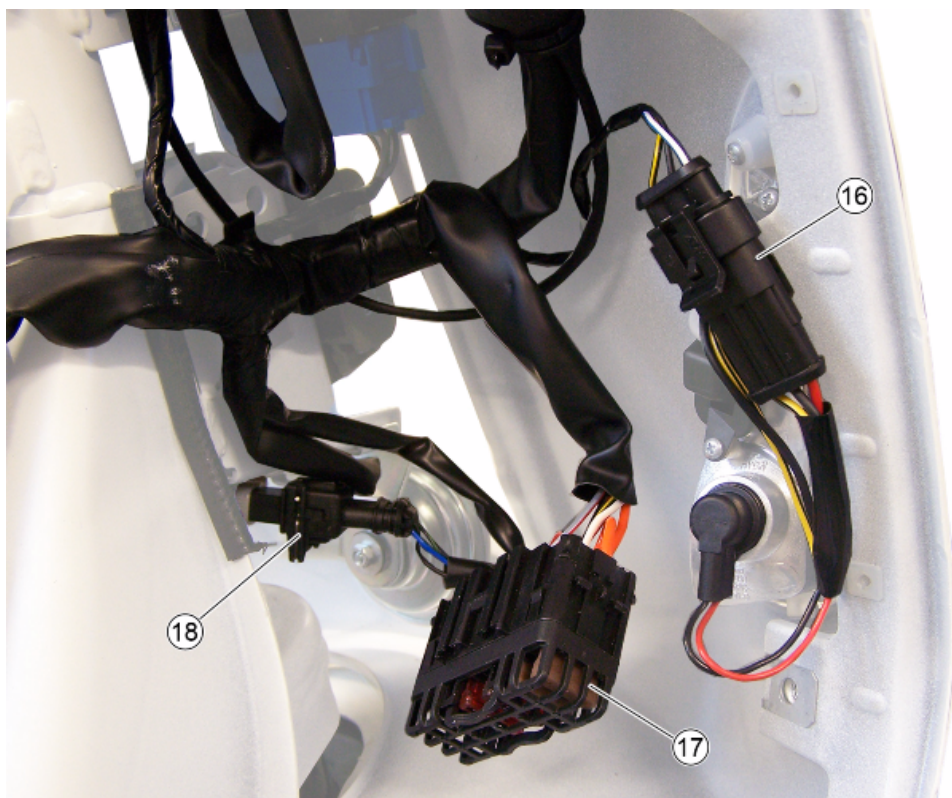

16. Front right turn indicator connector

17. Secondary fuses

18. Speed sensor connector

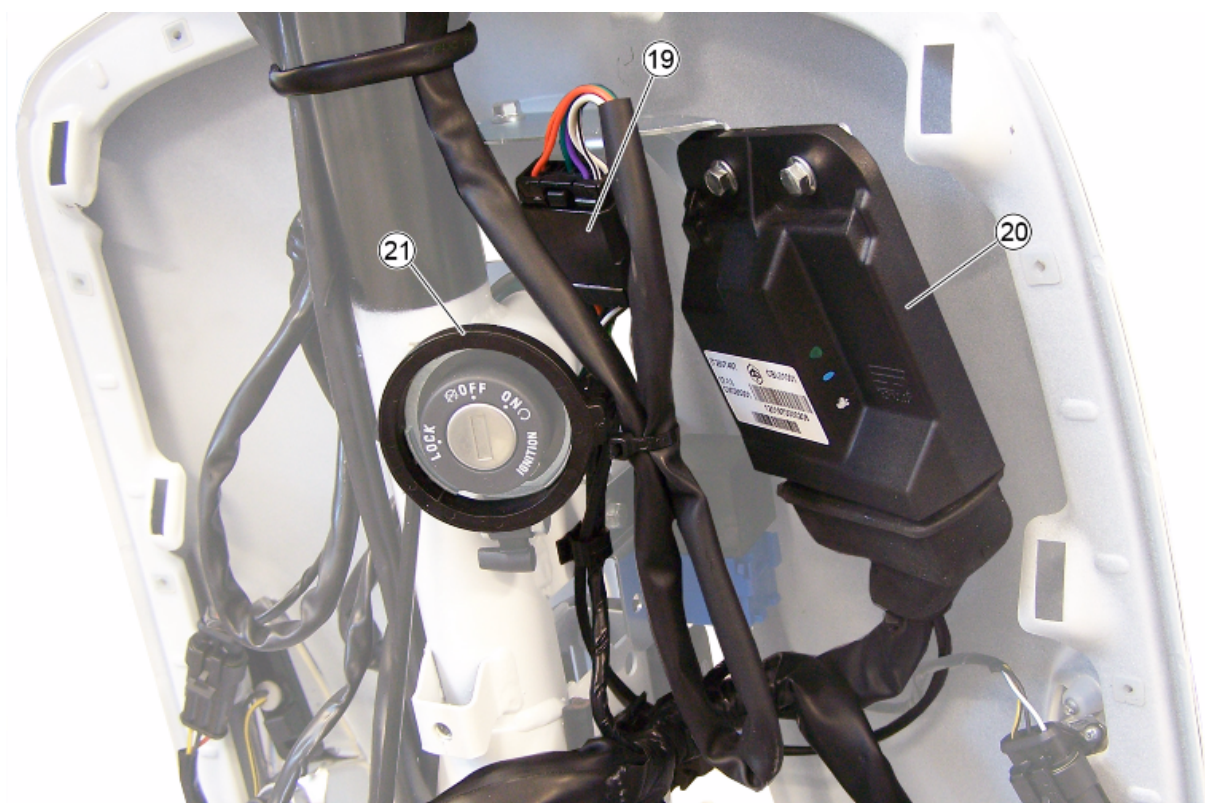

- 19. Right electrical controls connector
- 20. Injection ECU
- 21. Immobilizer antenna
- 22. ABS control unit (for applicable versions)



- 23. Ground point on chassis
  - 24. Negative battery pole
  - 25. Diagnostics socket
  - 26. Positive battery pole
  - 27. MAIN FUSE/S
  - 28. To rear cable harness
  - 29. Saddle opening actuator connector
-

## Back side

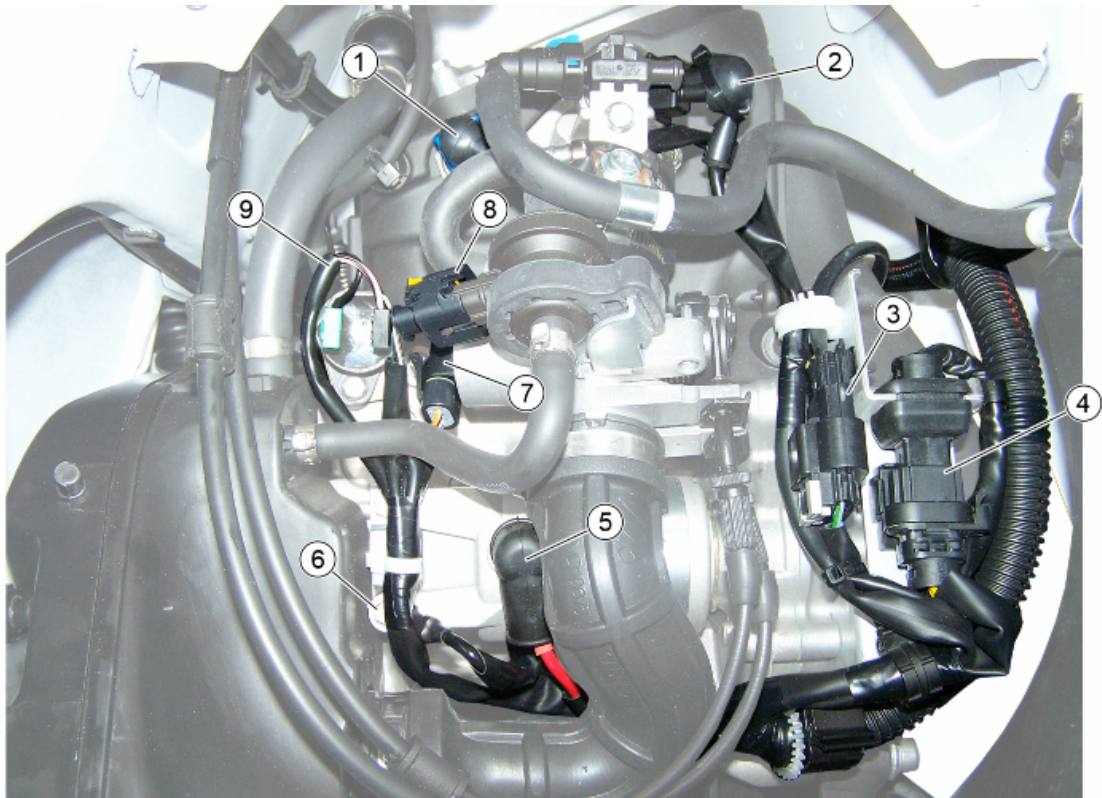

1. Engine temperature sensor connector
2. Injector connector
3. Lambda probe connector
4. Magneto flywheel connector
5. Starter motor positive
6. Starter motor negative
7. Throttle body position sensor connector
8. Idle valve connector
9. H.V. coil connections

---

## Checks and inspections

---

### Immobiliser

The electronic ignition system is controlled by the control unit with the integrated Immobilizer system. The Immobilizer is an antitheft system which allows the vehicle to function only if it is activated by means of the coded keys that the control unit recognises. The code is integrated in a transponder in the key block. This allows the driver clear operation without having to do anything other than just turning the key. The Immobilizer system consists of the following components:

- Control unit

- Immobilizer antenna
- master and service keys with built-in transponder
- H.V. coil
- diagnosis LED

The diagnosis LED also works as a theft-deterrent blinker. This function is activated every time the ignition switch is turned to "OFF" and it remains active 48 hours so as not to damage the battery charging process.

When the ignition switch is turned to "ON", it interrupts the function of the Immobilizer lamp and a start enable lamp comes "ON".

The duration of the flash depends on the programming of the electronic control unit.

If the LED is off regardless of the position of the ignition switch and/or the instrument panel is not initiated, check if:

- there is battery voltage
- the control unit is supplied.

---

## Virgin circuit

When the ignition system is not encrypted, any key will start the engine but limited to 2,000 rpm. The keys can only be recognised if the control unit has been programmed properly. The data storage procedure for a previously not programmed control unit provides for the recognition of the Master as the first key to be stored to memory: this becomes particularly important because it is the only key that enables the control unit to be wiped clean and reprogrammed for the memorisation of the service keys. The Master and service keys must be used to code the system as follows:

- Insert the Master key, turn it to «ON» and keep this position for two seconds (lower and upper limits 1 - 3 seconds).
- Insert the service key and turn it to "ON" for 2 seconds.
- If you have copies of the key, repeat the operation with each key.
- Insert the MASTER key again and turn it to «ON» for 2 seconds.

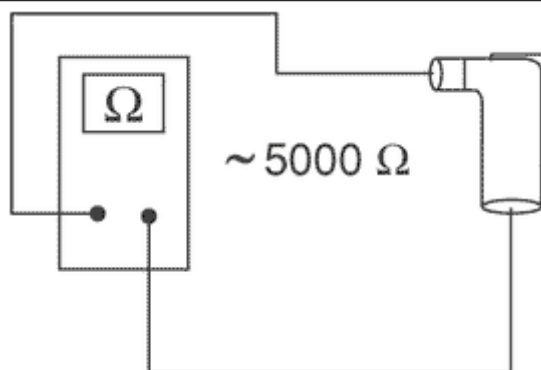

The maximum time to change keys is 10 seconds. A maximum of 7 service keys can be programmed at one time.

It is essential to adhere to the times and the procedure. If you do not, start again from the beginning. Once the system has been programmed, the master key transponder is strictly matched with the control unit. With this link established, it is now possible to encode new service keys, in the event of losses, replacements, etc. Each new programming deletes the previous one so, in order to add or eliminate keys, you must repeat the procedure using all the keys you intend to keep using. If a service key becomes uncoded, the efficiency of the high voltage circuit shielding must be thoroughly inspected. In any case it is advisable to use resistive spark plugs.

---

## Diagnostic codes

The Immobilizer system is tested each time the Ignition switch is turned from «OFF» to «ON». During this diagnosis phase a number of control unit statuses can be identified and various light codes displayed. Regardless of the code transmitted, if at the end of the diagnosis the LED remains off permanently, the ignition is enabled. If, however, the LED remains on permanently, it means the ignition is inhibited:

**1. Previously unused control unit - key inserted:** a single 2 second flash is displayed, after which the LED remains off permanently. The keys can be stored to memory, the vehicle can be started but with a limitation imposed on the number of revs.

**2. Previously unused control unit - transponder absent or cannot be used:** the LED is on

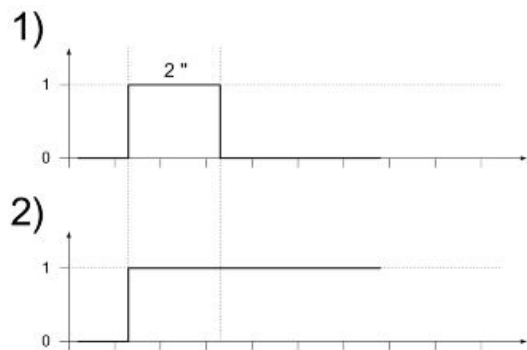

permanently. In this condition no operations are possible including the start up of the vehicle.

**3. Programmed control unit - the service key in (normal condition of use):** a single 0.7-second flash is displayed, after which the LED remains off steadily. The engine can be started.

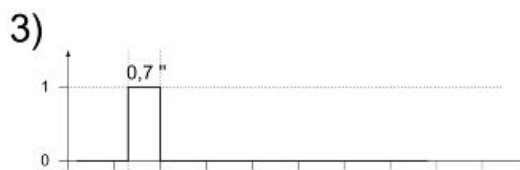

**4. Programmed control unit - Master key in:** a 0.7-sec flash is displayed followed by the LED remaining off for 2 sec.

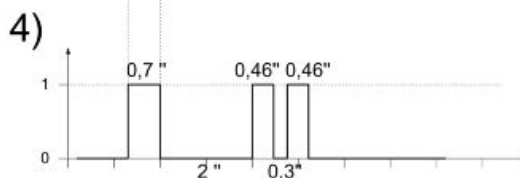

**5. Programmed control unit - fault detected:** a light code is displayed according to the fault detected, after which the LED remains on steadily. The engine cannot be started, but the operation of the starter motor is not disabled. The codes that can be transmitted are:

- 1-flash code
- 2-flash code
- 3-flash code

## Diagnostic code - 1 flash

A one-flash code indicates a system where the serial line is not present or is not detected. Check the Immobilizer antenna wiring and change it if necessary.

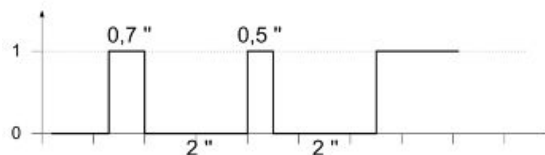

## Diagnostic code - 2 flashes

A two-flash code shows a system where the control unit does not show the transponder signal. This might depend on the inefficiency of the Immobilizer antenna or the transponder.

Turn the switch to ON using several keys: if the code is repeated even with the Master key, check the antenna wiring and change it if necessary. If this is not the case, replace the defective key and/

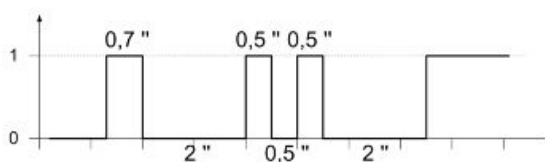

or reprogram the control unit. Replace the control unit if the problem continues.

---

## Diagnostic code - 3 flashes

A three-flash code indicates a system where the control unit does not recognise the key. Turn the switch to ON using several keys: if the error code is repeated even with the Master key, replace the control unit. If this is not the case, reprogram the decoder.

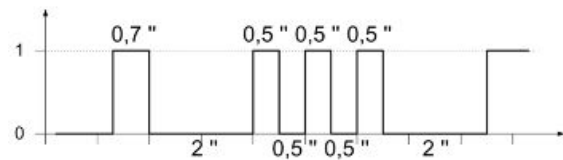

---

## Battery recharge circuit

The charging circuit consists of three-phase alternator and a permanent magneto flywheel.

The alternator is directly connected to the voltage regulator.

This, in its turn, is connected directly to the ground and the battery's positive terminal passing through the 20A protective fuse.

The three-phase alternator provides good recharge power and at low revs a good compromise is achieved between generated power and idle stability.

---

## Recharge system voltage check

### Look for any leakage

- 1) Access the battery by removing the specific cover.
- 2) Check that the battery does not show signs of losing fluid before checking the output voltage.
- 3) Turn the ignition key to position OFF, connect the terminals of the tester between the negative pole (-) of the battery and the black cable and only then disconnect the black cable from the negative pole (-) of the battery.
- 4) With the ignition key always at OFF, the reading indicated by the ammeter must be  $\leq 0.5$  mA.

### Charging current check

#### WARNING

**BEFORE CARRYING OUT THE CHECK, MAKE SURE THAT THE BATTERY IS IN GOOD WORKING ORDER.**

- 1) Place the vehicle on its centre stand.
- 2) With the battery correctly connected to the circuit, place the multimeter leads between the battery terminals..
- 3) Start the engine, ensure that the lights are all out, increase the engine speed and at the same time measure the voltage.



**Electric characteristic**

Voltage ranging between 14.0 and 15.0V at 5,000 rpm.

**VOLTAGE REGULATOR/RECTIFIER**

Specification	Desc./Quantity
Type	Non-adjustable three-phase transistor
Voltage	14 - 15V at 5,000 rpm with lights off

**level indicators****WARNING**

**ALL CONTINUITY TESTS MUST BE CARRIED OUT WITH THE CORRESPONDING CONNECTORS DISCONNECTED.**

If faults are detected:

- 1) With a multimeter, check resistance values between the White-Green cable and the Black cable of the fuel level transmitter under different conditions.
- 2) If the transmitter operates correctly but the indication on the instrument panel is not exact, check that the wiring harnesses between them are not interrupted.

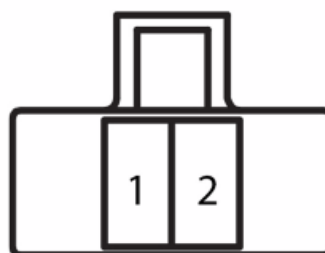
**Electric characteristic****Resistance value with full tank**

$\leq 7 \Omega$

**Resistance value with empty tank**

$90 + 13/-3 \Omega$

**Lights list****BULBS**

	Specification	Desc./Quantity
1	High beam / low beam bulb	<b>Type:</b> Halogen (HS1) <b>Power:</b> 12V - 35/35W <b>Quantity:</b> 1
2	Front daylight running light bulb	<b>Type:</b> LED <b>Quantity:</b> 2
3	Stop light bulb	<b>Type:</b> Incandescent <b>Power:</b> 12V - 21W <b>Quantity:</b> 1
4	Rear daylight running light bulb	<b>Type:</b> Incandescent <b>Power:</b> 12V - 5W <b>Quantity:</b> 2
5	Licence plate light bulb	<b>Type:</b> incandescent <b>Power:</b> 12V - 5W <b>Quantity:</b> 1
6	Front indicator light bulb	<b>Type:</b> Halogen, BAZ9s base, amber <b>Power:</b> 12V - 6W <b>Quantity:</b> 1 RH + 1 LH
7	Rear indicator light bulb	<b>Type:</b> Halogen, BAZ9s base, amber

Specification	Desc./Quantity
	<b>Power:</b> 12V - 6W <b>Quantity:</b> 1 RH + 1 LH

**FOR VERSIONS MY2018 - MY2020**

**BULBS**

Specification	Desc./Quantity
1 High beam / low beam bulb	<b>Type:</b> LED <b>Quantity:</b> 2
2 Front daylight running light bulb	<b>Type:</b> LED <b>Quantity:</b> 2
3 Stop light bulb	<b>Type:</b> LED <b>Quantity:</b> 1
4 rear daylight running light bulb	<b>Type:</b> incandescent <b>Power:</b> 12V - 10W <b>Quantity:</b> 1
5 Licence plate light bulb	<b>Type:</b> incandescent <b>Power:</b> 12V - 5W <b>Quantity:</b> 1
6 Front indicator light bulb	<b>Type:</b> Halogen, BAZ9s base, amber <b>Power:</b> 12V - 6W <b>Quantity:</b> 1 RH + 1 LH
7 Rear indicator light bulb	<b>Type:</b> Halogen, BAZ9s base, amber <b>Power:</b> 12V - 6W <b>Quantity:</b> 1 RH + 1 LH

**Fuses**

The electrical system is protected by a main fuse (two for the ABS versions) and six secondary fuses, positioned as:

**MAIN FUSES «A»:** battery compartment.

**Access to the main fuses «A»:**

- Remove the battery compartment cover as described in the "Battery" paragraph.
- Open the fuse holders.

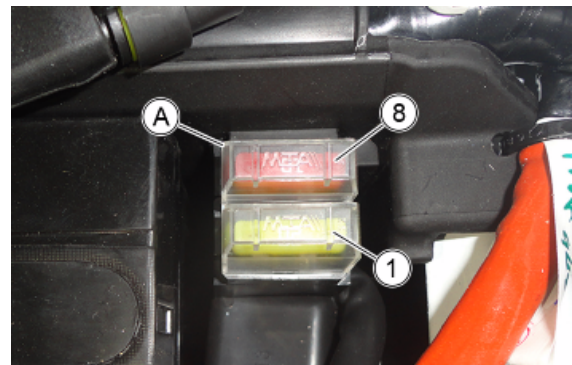

**MAIN FUSES**

Specification	Desc./Quantity
1 Fuse No. 1	<b>Capacity:</b> 20 A <b>Protected circuits:</b> General live supply, fuses 6 and 7, battery recharge.
2 Fuse no. 8 (ABS version)	<b>Capacity:</b> 10 A <b>Protected circuits:</b> ABS control unit.

**SECONDARY FUSES «B»:** in the front case.

**Access to secondary fuses «B»:**

- Open the front case.
- Open the fuse holders.

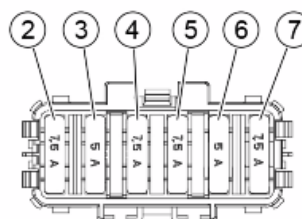
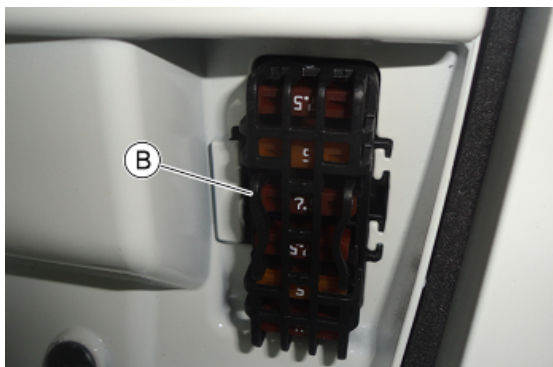

### SECONDARY FUSES

	Specification	Desc./Quantity
1	Fuse no. 2	<b>Capacity:</b> 7.5 A <b>Protected circuits (live):</b> USB port, stop light, horn, turn indicator, instrument panel.
2	Fuse No. 3	<b>Capacity:</b> 5 A <b>Protected circuits (live):</b> ABS control unit (versions where provided), injection control unit.
3	Fuse No. 4	<b>Capacity:</b> 7.5 A <b>Protected circuits (live):</b> daylight running light, high beam and low beam lights.
4	Fuse No. 5	<b>Capacity:</b> 7.5 A <b>Protected circuits (live):</b> high beam light flashing.
5	Fuse No. 6	<b>Capacity:</b> 5 A <b>Protected circuits:</b> Saddle opening actuator.
6	Fuse No. 7	<b>Capacity:</b> 7.5 A <b>Protected circuits:</b> Instrument panel, injection control unit.

CAUTION



**ELIMINATE THE CAUSE OF THE FAULT BEFORE REPLACING THE FUSE.  
WE STRONGLY RECOMMEND THAT YOU CONTACT AN AUTHORISED SERVICE CENTRE.**

CAUTION



**IN ORDER TO AVOID DAMAGING THE ELECTRICAL SYSTEM, NEVER DISCONNECT THE WIRING WHILE THE ENGINE IS RUNNING. DO NOT TIP THE VEHICLE TOO MUCH IN ORDER TO AVOID DANGEROUS LEAKAGE OF THE BATTERY ELECTROLYTE.**

CAUTION



**MODIFICATIONS OR REPAIRS TO THE ELECTRICAL SYSTEM, PERFORMED INCORRECTLY OR WITHOUT STRICT ATTENTION TO THE TECHNICAL SPECIFICATIONS OF THE SYSTEM CAN CAUSE MALFUNCTIONING AND RISK OF FIRE.**

**CAUTION**



**PROCEED WITH CAUTION.**

**DO NOT DAMAGE THE TABS AND/OR THEIR CORRESPONDING SLOTS. HANDLE THE PLASTIC AND PAINTED COMPONENTS WITH CARE, DO NOT SCRATCH OR IMPAIR THEM.**

**FOR VERSIONS MY2018 - MY2020**

The electrical system has 2 main fuses located inside the battery compartment, and 6 secondary fuses located inside the front case.

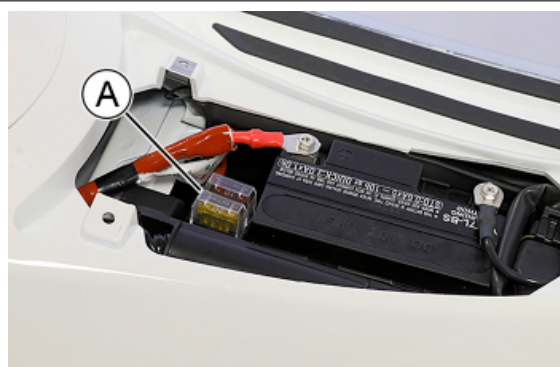

**CAUTION**



**IN ORDER TO AVOID DAMAGING THE ELECTRICAL SYSTEM, NEVER DISCONNECT THE WIRING WHILE THE ENGINE IS RUNNING. DO NOT TIP THE VEHICLE TOO MUCH IN ORDER TO AVOID DANGEROUS LEAKAGE OF THE BATTERY ELECTROLYTE.**

**CAUTION**



**MODIFICATIONS OR REPAIRS TO THE ELECTRICAL SYSTEM, PERFORMED INCORRECTLY OR WITHOUT STRICT ATTENTION TO THE TECHNICAL SPECIFICATIONS OF THE SYSTEM CAN CAUSE MALFUNCTIONING AND RISK OF FIRE.**

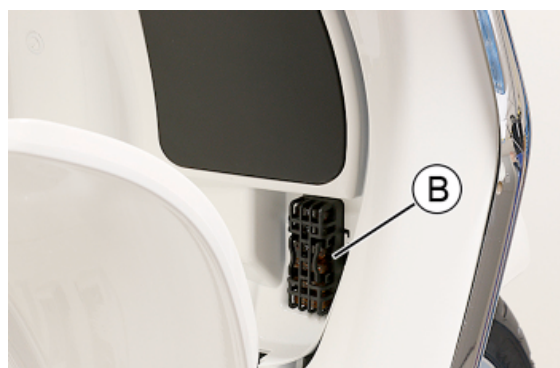

**CAUTION**



**PROCEED WITH CAUTION. DO NOT DAMAGE THE TABS AND/OR THEIR CORRESPONDING SLOTS. HANDLE THE PLASTIC AND PAINTED COMPONENTS WITH CARE, DO NOT SCRATCH OR IMPAIR THEM.**

**MAIN FUSES**

The location and characteristics of the vehicle's 2 main fuses are indicated in the table.

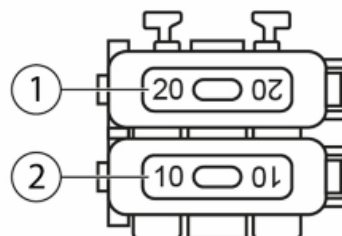

**MAIN FUSES TABLE**

	Specification	Desc./Quantity
1	Fuse 1	Capacity: 20A

Specification	Desc./Quantity
	<b>Protected circuits:</b> main. <b>Ignition switched live:</b> fuse Ns. 3, 4, 5 and 6.
2	Fuse No. 2 <b>Capacity:</b> 10A <b>Protected circuits:</b> battery-powered, ABS control unit.

## SECONDARY FUSES

The location and characteristics of the vehicle's 6 secondary fuses are indicated in the table.

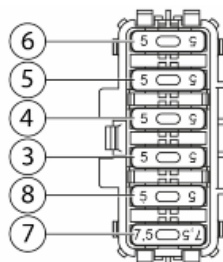

## SECONDARY FUSES TABLE

Specification	Desc./Quantity
1	Fuse 3 <b>Capacity:</b> 5A <b>Protected circuits:</b> - ignition switch controlled power supply for low beam lights, high beam lights, daylight running light, licence plate light.
2	Fuse 4 <b>Capacity:</b> 5A <b>Protected circuits:</b> ignition switch controlled power supply high beam light (passing), USB port..
3	Fuse 5 <b>Capacity:</b> 5A <b>Protected circuits:</b> ignition switched controlled power supply for ABS control unit, engine management control unit.
4	Fuse 6 <b>Capacity:</b> 5A <b>Protected circuits:</b> ignition switched controlled power for supply instrument panel, signal lights control device, horn, starter relay (coil), brake light.
5	Fuse 7 <b>Capacity:</b> 7.5 A <b>Protected circuits:</b> power supply from the engine management control unit.
6	Fuse 8 <b>Capacity:</b> 5A <b>Protected circuits:</b> battery power supply for instrument panel. <b>Ignition switched live:</b> saddle actuator.

## FOR CHINA MARKET

## SECONDARY FUSES TABLE

Specification	Desc./Quantity
1	Fuse 3 <b>Capacity:</b> 5A <b>Protected circuits:</b> - ignition switch controlled power supply for low beam lights, high beam lights, daylight running light, licence plate light.
2	Fuse 4 <b>Capacity:</b> 5A <b>Protected circuits:</b> ignition switch controlled power supply for high beam light (passing), USB port, OBD port.
3	Fuse 5 <b>Capacity:</b> 5A <b>Protected circuits:</b> ignition switched controlled power supply for ABS control unit, engine management control unit.
4	Fuse 6 <b>Capacity:</b> 5A <b>Protected circuits:</b> ignition switched controlled power for supply instrument panel, signal lights control device, horn, starter relay (coil), brake light.
5	Fuse 7 <b>Capacity:</b> 7.5 A <b>Protected circuits:</b> power supply from the engine management control unit.
6	Fuse 8 <b>Capacity:</b> 5A <b>Protected circuits:</b> battery power supply for instrument panel, OBD port.

Specification	Desc./Quantity
	Ignition switched live: saddle actuator.

**FOR THE VERSION WITH "TFT" INSTRUMENT PANEL**

The electrical system has 2 main fuses located inside the battery compartment, and 6 secondary fuses located inside the front case.

**CAUTION**



ELIMINATE THE CAUSE OF THE FAULT BEFORE REPLACING THE FUSE.  
WE STRONGLY RECOMMEND THAT YOU CONTACT AN AUTHORISED SERVICE CENTRE.

**CAUTION**



MODIFICATIONS OR REPAIRS TO THE ELECTRICAL SYSTEM, PERFORMED INCORRECTLY OR WITHOUT STRICT ATTENTION TO THE TECHNICAL SPECIFICATIONS OF THE SYSTEM CAN CAUSE MALFUNCTIONING AND RISK OF FIRE.



**MAIN FUSES**

The location and characteristics of the vehicle's 2 main fuses are indicated in the table.

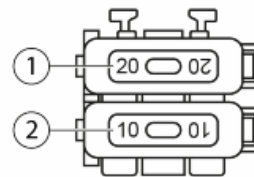

**MAIN FUSES TABLE**

Specification	Desc./Quantity
1 Fuse 1	<b>Capacity: 20A</b> <b>Protected circuits:</b> main, fuses No. 7 and 8. <b>Ignition switched live:</b> fuses No. 3, 4, 5 and 6.
2 Fuse No. 2	<b>Capacity: 10A</b> <b>Protected circuits:</b> battery-powered, ABS control unit.

**SECONDARY FUSES (for EURO 5 version)**

The location and characteristics of the vehicle's 6 secondary fuses are indicated in the table.

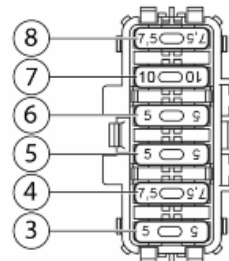

**TABLE OF SECONDARY FUSES (FOR EURO 5 VERSION)**

Specification	Desc./Quantity
1 Fuse No. 3	<b>Capacity: 5A</b> <b>Protected circuits:</b> low beam light and high beam light ignition switched live.
2 Fuse 4	<b>Capacity: 7.5 A</b>

	Specification	Desc./Quantity
		<b>Protected circuits:</b> ignition switched live, high beam light (passing), USB port, position lights, licence plate light, bike finder, accessories provision, diagnostics port.
3	Fuse 5	<b>Capacity:</b> 5A <b>Protected circuits:</b> ignition switched live for ABS ECU, tip over sensor, engine management ECU, immobilizer aerial, injection load relay.
4	Fuse 6	<b>Capacity:</b> 5A <b>Protected circuits:</b> ignition switched live instrument cluster, digital display, flashers control device, VMP control unit (Vespa Multimedia Platform), horn, brake lights, starter relay (coil).
5	Fuse 7	<b>Capacity:</b> 10A <b>Protected circuits:</b> battery-powered, engine control unit, injection load relay.
6	Fuse 8	<b>Capacity:</b> 7.5 A <b>Protected circuits:</b> battery powered instrument cluster, digital display, ignition switch, saddle opening button, accessory set-up, bike finder, diagnostics port.

### SECONDARY FUSES (for EURO 3 - EURO 4 versions)

The location and characteristics of the vehicle's 6 secondary fuses are indicated in the table.

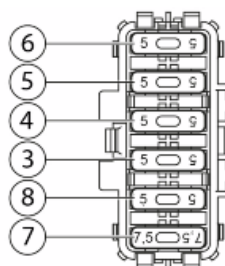

### TABLE OF SECONDARY FUSES (FOR EURO 3 - EURO 4 VERSIONS)

	Specification	Desc./Quantity
1	Fuse 3	<b>Capacity:</b> 5A <b>Protected circuits:</b> - ignition switch controlled power supply for low beam lights, high beam lights, daylight running light, licence plate light.
2	Fuse 4	<b>Capacity:</b> 5A <b>Protected circuits:</b> ignition switch controlled power supply high beam light (passing), USB port..
3	Fuse 5	<b>Capacity:</b> 5A <b>Protected circuits:</b> ignition switched controlled power supply for ABS control unit, engine management control unit.
4	Fuse 6	<b>Capacity:</b> 5A <b>Protected circuits:</b> ignition switched live instrument cluster, digital display, flashers control device, VMP control unit (Vespa Multimedia Platform), horn, brake lights, starter relay (coil).
5	Fuse 7	<b>Capacity:</b> 7.5 A <b>Protected circuits:</b> power supply from the engine management control unit.
6	Fuse 8	<b>Capacity:</b> 5A <b>Protected circuits:</b> battery powered instrument cluster, digital display, ignition switch, saddle opening button.

### FOR CHINA VERSION

#### SECONDARY FUSES TABLE

	Specification	Desc./Quantity
1	Fuse 3	<b>Capacity:</b> 5A <b>Protected circuits:</b> - ignition switch controlled power supply for low beam lights, high beam lights, daylight running light, licence plate light.
2	Fuse 4	<b>Capacity:</b> 5A

	Specification	Desc./Quantity
		<b>Protected circuits:</b> ignition switch controlled power supply for high beam light (passing), USB port, OBD port.
3	Fuse 5	<b>Capacity:</b> 5A <b>Protected circuits:</b> ignition switched controlled power supply for ABS control unit, engine management control unit.
4	Fuse 6	<b>Capacity:</b> 5A <b>Protected circuits:</b> ignition switched controlled power for supply instrument panel, signal lights control device, horn, starter relay (coil), brake light.
5	Fuse 7	<b>Capacity:</b> 7.5 A <b>Protected circuits:</b> power supply from the engine management control unit.
6	Fuse 8	<b>Capacity:</b> 5A <b>Protected circuits:</b> battery power supply for instrument panel, OBD port. <b>Ignition switched live:</b> saddle actuator.

## Sealed battery

If the vehicle is provided with a sealed battery, the only maintenance required is the check of its charge and recharging, if necessary.

These operations should be carried out before delivering the vehicle, and on a six-month basis while the vehicle is stored in open circuit.

Besides upon pre-delivery it is therefore necessary to check the battery charge and recharge it, if required, before storing the vehicle and afterwards every six months.

### INSTRUCTIONS FOR BATTERY REFRESH AFTER OPEN CIRCUIT STORAGE

#### 1) Voltage check

Before installing the battery on the vehicle, check the open circuit voltage with a standard tester.

- If voltage exceeds 12.60 V, the battery can be installed without any renewal recharge.
- If voltage is below 12.60 V, a renewal recharge is required as explained in 2).

#### 2) Constant voltage battery charge mode

- Constant voltage charge equal to 14.40 - 14.70V
- Initial charge voltage equal to 0.3 - 0.5 for Nominal capacity
- Charge time:  
10 - 12 h recommended

Minimum 6 h

Maximum 24 h

#### 3) Constant current battery charge mode

- Charge current equal to 1/10 of the battery rated capacity
- Charge time: Maximum 5 h

## Battery installation

### VRLA battery (valve-regulated lead-acid battery) Maintenance Free (MF)

#### WARNING



**BATTERY ELECTROLYTE IS TOXIC AND IT MAY CAUSE SERIOUS BURNS. IT CONTAINS SULPHURIC ACID. AVOID CONTACT WITH EYES, SKIN AND CLOTHING. IF IT ACCIDENTALLY COMES INTO CONTACT WITH YOUR EYES OR SKIN, WASH WITH ABUNDANT WATER FOR APPROX. 15 MIN. AND SEEK IMMEDIATE MEDICAL ATTENTION.**

**IN THE EVENT OF ACCIDENTAL INGESTION OF THE LIQUID, IMMEDIATELY DRINK LARGE QUANTITIES OF WATER OR MILK. MAGNESIUM MILK, BATTERED EGG OR VEGETABLE OIL. SEEK IMMEDIATE MEDICAL ATTENTION.**

**BATTERIES PRODUCE EXPLOSIVE GAS; KEEP CLEAR OF NAKED FLAMES, SPARKS OR CIGARETTES; VENTILATE THE AREA WHEN RECHARGING INDOORS.**

**ALWAYS WEAR EYE PROTECTION WHEN WORKING IN THE PROXIMITY OF BATTERIES. KEEP OUT OF THE REACH OF CHILDREN.**

### 1) Battery preparation

Position the battery on a flat surface. Remove the adhesive sheet closing cells and proceed as quickly as possible to run the subsequent activation phases.



### 2) Electrolyte preparation.

Remove the container of the electrolyte from the pack. Remove and preserve cover strips from the container, in fact, the strip will later be used as a closing cover.

**Note:** Do not pierce the sealing of the container or the container itself because inside there is sulphuric acid.

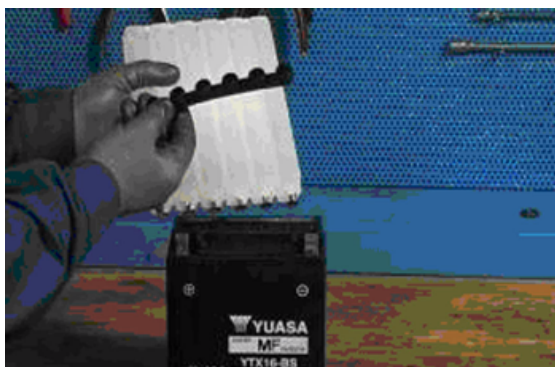

### 3) Procedure for filling the battery with acid.

Position the electrolyte container upside down with the six areas sealed in line with the six battery filler holes. Push the container down with enough force to break the seals. The electrolyte should start to flow inside the battery.

**Note:** Do not tilt the container to prevent the flow of electrolyte from pausing or stopping.



### 4) Control the flow of electrolyte

Make sure air bubbles are rising from all six filling holes. Leave the container in this position for 20 minutes or more.

**Note:** If there are no air bubbles coming out of the filling holes, lightly tap the bottom of the container two or three times. Do not remove the container from the battery.

### 5) Take out the container.

Make sure all the electrolyte in the battery is drained. Gently tap the bottom of the container if electrolyte remains in the container. Only once the container is completely empty, gently remove the container itself from the battery. Leave the battery to rest, without sealing the six cells, for at least 1 hour before charging.

#### 6) Recharging the new battery

With the above-mentioned procedure, the battery will have gained around 70% - 75% of its total electrical capacity. Before installing the battery on the vehicle, it must be fully charged and then must be recharged.

**If the battery is to be installed on the vehicle prior to this pre-charged one, the battery will not be able to exceed 75% charge without jeopardising its useful life on vehicle.**

The dry charge battery MF like the completely loaded YTX, must have a zero load voltage between 12.8 - 13.15 V Bring the battery to full charge, using the 020648Y battery charger:

- a - select the type of battery with the red switch on the left of the panel battery charger panel
- b - select NEW on the yellow timer
- c - connect the clamps of the battery charger to the battery poles (black clamp to negative pole (-) and red clamp to positive pole (+)).
- d - Press the red button, as shown in figure.

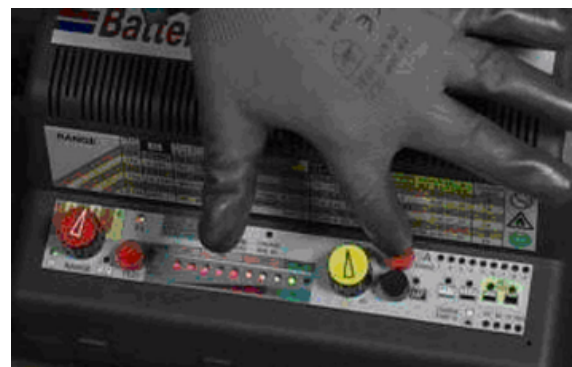

e - Press the "MF" black button to activate the battery recharge **Maintenance Free** as shown in figure.



f - Check the ignition of the green LED indicated with a red arrow in figure.



g - The activation cycle of the new battery lasts for 30 minutes after the ignition of the recharge LED has taken place



h - Disconnect the clamps from the battery and check the voltage, if voltages are detected of less than 12.8 V, proceed with a new recharge of the battery starting from point c of the recharge procedure of **the new battery**, otherwise go to point i



i - The battery is now properly activated, disconnect the battery charger from the power supply and unplug the terminals from the battery.

### 7) Battery closing.

Insert the airtight cover strips into the filling holes.

Press horizontally with both hands and make sure that the strip is levelled with the top part of the battery.

**Note:** To do this, do not use sharp objects that could damage the closing strip, use gloves to protect your hands and do not bring your face close to the battery.

The filling process is now complete.

Do not remove the strip of caps under any circumstances, do not add water or electrolyte.

Assembly procedure of the battery on the vehicle.

## Connectors

### DIAGNOSTIC CONNECTOR

1. Not connected
2. Ground lead (Black)
3. Electronic control unit (Orange-Black)

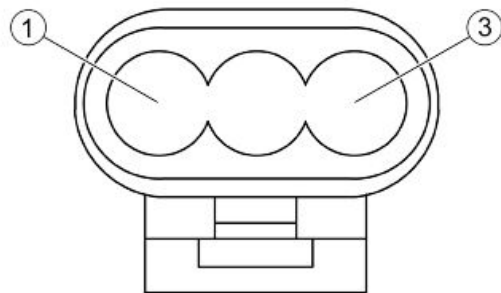

### FLYWHEEL

- a1. Gi - Voltage regulator
- b1. GrVe - Pickup -
- c1. Gi - Voltage regulator
- a2. RoBi - Engine oil pressure sensor
- b2. Gi - Voltage regulator
- c2. Rs - pickup +

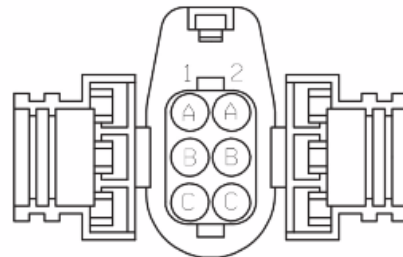

### FUEL PUMP CONNECTOR

1. Not connected
2. Negative from control unit (Green)
3. Not connected
4. Not connected
5. Power from control unit (Black - Green)

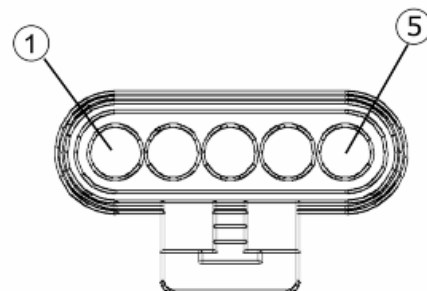

**INJECTION ECU**

1. Ve - fuel pump
2. MaBi - injection warning light
3. AzRs -lambda probe heater
4. Gi - immobilizer LED
5. RsBi - + battery
6. RsGi - injector ground
7. GrVe - sensor ground
8. RoNe - + H.V. coil
9. NeVe - + loads
10. ArNe - K Line
11. VeGi - enable start
12. Rs - pickup +
13. VeBL - Lambda +
14. ArBi - TPS sensor
15. Ar - side stand switch
16. AzVe - engine temperature sensor
17. BiNe - idle regulator valve
18. RsNe - +5V sensors
19. Ne - ground
20. RsBL - + key-on power

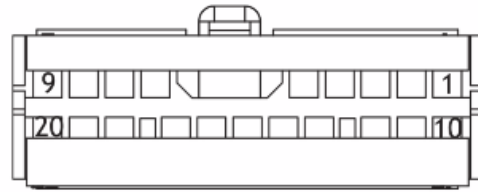
**ENGINE TEMPERATURE SENSOR CONNECTOR**

1. Electronic control unit (Sky blue - Green)
2. Ground lead (Grey-Green)

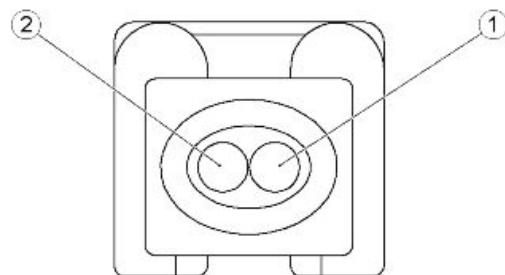
**INJECTOR CONNECTOR**

1. Negative from control unit (Red-Yellow)
2. Power from control unit (Black - Green)

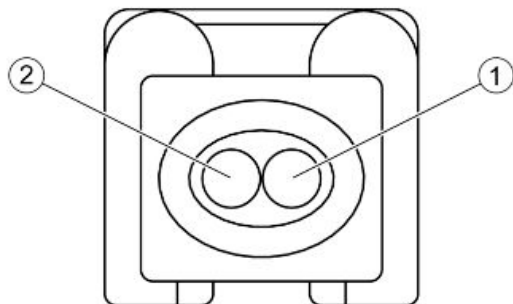

**LAMBDA PROBE CONNECTOR**

1. Lambda signal positive (Green-Blue)
2. Lambda signal negative (Grey-Green)
3. Heater ECU negative (Light blue-Red)
4. Heater supply from ECU (Black-Green)

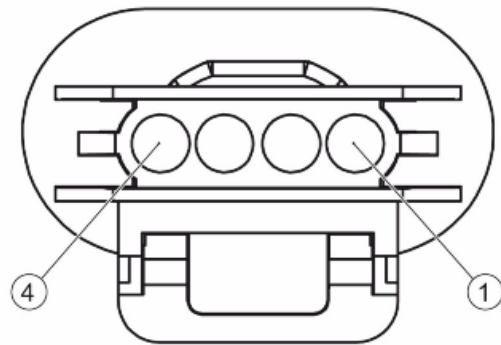

**VOLTAGE REGULATOR**

1. RsNe - positive
2. not connected
3. Ne - ground
4. Gi - flywheel
5. Gi - flywheel
6. Gi - flywheel

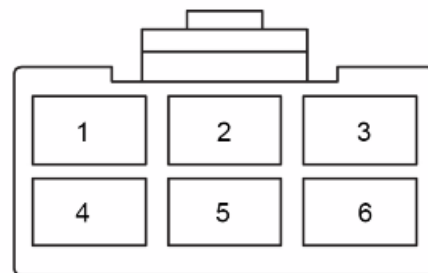

**INSTRUMENT PANEL CONNECTOR (ABS VERSIONS)**

1. Oil pressure sensor (Pink-White)
2. MODE button (Green)
3. Left turn indicator warning light (Pink)
4. Right turn indicator warning light (White-Blue)
5. High beam warning light (Purple)
6. ABS warning light (Blue)
7. Not connected
8. Not connected
9. Not connected
10. Not connected
11. Not connected
12. Fuel level indicator (White - Green)
13. Not connected
14. Speed sensor signal (Sky blue)
15. Not connected
16. Injection warning light (Brown-White)
17. Ground lead (Black)
18. Immobilizer LED (Yellow)

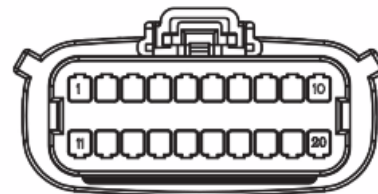

**19.** Ignition switched live and Instrument panel lighting (White)

**20.** Battery power (Red-White)

---

**INSTRUMENT PANEL CONNECTOR (NON ABS VERSIONS)**

1. Oil pressure sensor (Pink-White)
2. MODE button (Green)
3. Left turn indicator warning light (Pink)
4. Right turn indicator warning light (White-Blue)
5. High beam warning light (Purple)
6. Not connected
7. Not connected
8. Speed sensor negative (Black-Green)
9. Not connected
10. Not connected
11. Not connected
12. Fuel level indicator (White - Green)
13. Not connected
14. Speed sensor signal (Sky blue)
15. Not connected
16. Injection warning light (Brown-White)
17. Ground lead (Black)
18. Immobilizer LED (Yellow)
19. Ignition switched live and Instrument panel lighting (White)
20. Battery power (Red-White)

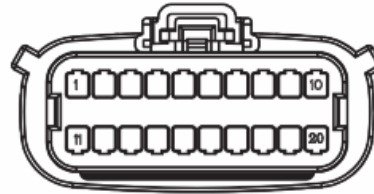



---

**H.V. COIL.**

1. RoNe (black) - control unit
2. Ne (green) - ground

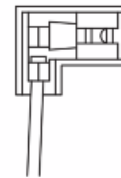

1



2

**FUEL LEVEL TRANSMITTER CONNECTOR**

1. Fuel level indicator (White - Green)
2. Ground lead (Black)

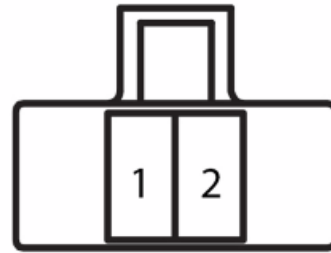

**ABS CONTROL UNIT CONNECTOR**

1. Not connected
2. Ground lead (Black)
3. Speed sensor positive (Light Blue-Red)
4. Speed sensor negative (Ligh Blue-Black)
5. Not connected
6. Not connected
7. Not connected
8. Not connected
9. Line K (Orange-Black)
10. ABS warning light (Blue)
11. Vehicle speed signal (Sky blue)
12. Not connected
13. Battery powered (Red-Green)
14. Ignition switched live (Red-Blue)

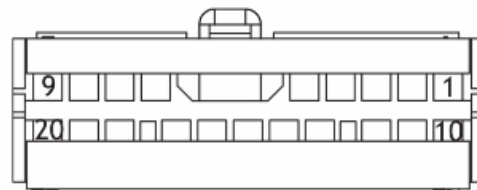

**FOR VERSIONS MY2018 - MY2020**

**DIAGNOSTIC CONNECTOR**

1. Not connected
2. Ground lead (Black)
3. Electronic control unit (Orange-Black)

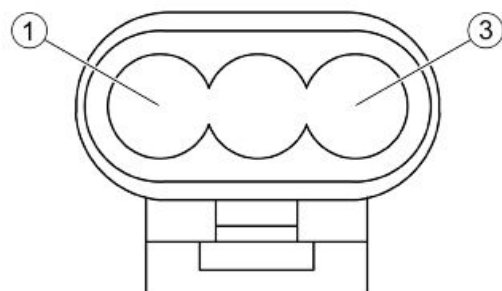



**FLYWHEEL**

- a1. Gi - Voltage regulator
- b1. GrVe - Pickup -
- c1. Gi - Voltage regulator
- a2. RoBi - Engine oil pressure sensor
- b2. Gi - Voltage regulator
- c2. Rs - pickup +

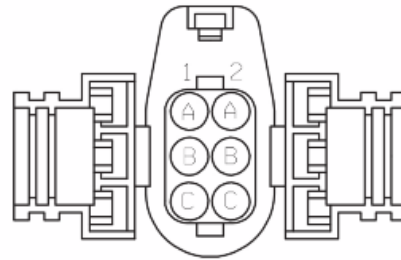
**FUEL PUMP CONNECTOR**

- 1. Not connected
- 2. Negative from control unit (Green)
- 3. Not connected
- 4. Not connected
- 5. Power from control unit (Black - Green)

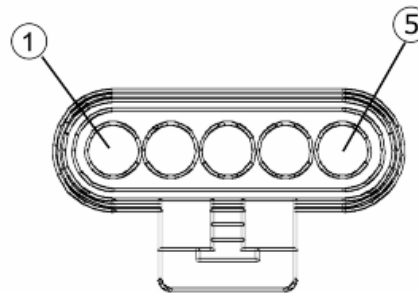
**INJECTION ECU**

- 1. Ve - fuel pump
- 2. MaBi - injection warning light
- 3. AzRs -lambda probe heater
- 4. Gi - immobilizer LED
- 5. RsBi - + battery
- 6. RsGi - injector ground
- 7. GrVe - sensor ground
- 8. RoNe - + H.V. coil
- 9. NeVe - + loads
- 10. ArNe - K Line
- 11. VeGi - ignition activation / VeBi - canister valve  
(if applicable)
- 12. Rs - pickup +
- 13. VeBL - Lambda +
- 14. ArBi - TPS sensor
- 15. Ar - side stand switch
- 16. AzVe - engine temperature sensor
- 17. BiNe - idle regulator valve
- 18. RsNe - +5V sensors
- 19. Ne - ground

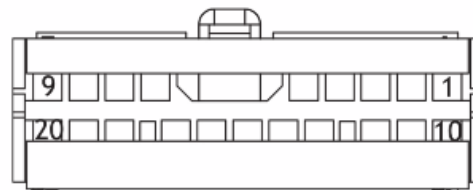

20. RsBL - + key-on power

**ENGINE TEMPERATURE SENSOR CONNECTOR**

1. Electronic control unit (Sky blue - Green)
2. Ground lead (Grey-Green)

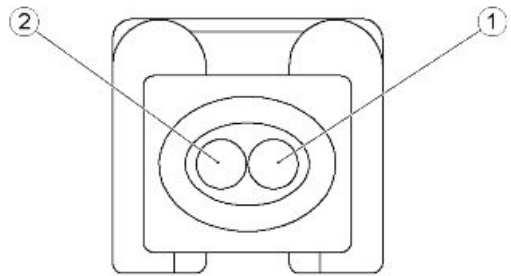

**INJECTOR CONNECTOR**

1. Negative from control unit (Red-Yellow)
2. Power from control unit (Black - Green)

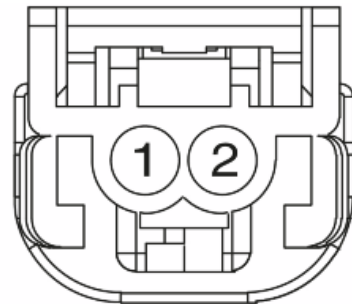

**LAMBDA PROBE CONNECTOR**

1. Lambda signal positive (Green-Blue)
2. Lambda signal negative (Grey-Green)
3. Heater ECU negative (Light blue-Red)
4. Heater supply from ECU (Black-Green)

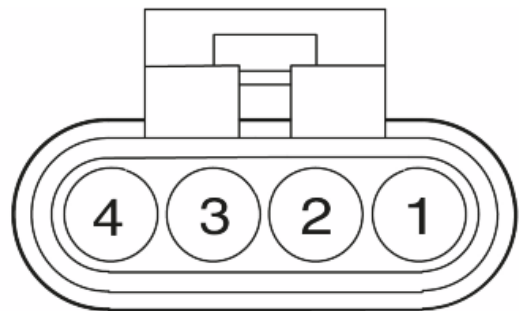

**VOLTAGE REGULATOR**

1. RsNe - positive
2. not connected
3. Ne - ground
4. Gi - flywheel
5. Gi - flywheel
6. Gi - flywheel

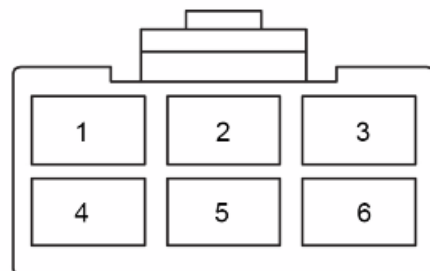

**INSTRUMENT CLUSTER**

1. Oil pressure sensor (Pink-White)
2. MODE button (Green)
3. Left turn indicator warning light (Pink)
4. Right turn indicator warning light (White-Blue)
5. High beam warning light (Purple)
6. ABS warning light (Blue)
7. Not connected
8. Not connected
9. Not connected
10. Not connected
11. Not connected
12. Fuel level indicator (White - Green)
13. Not connected
14. Speed sensor signal (Sky blue)
15. Not connected
16. Injection warning light (Brown-White)
17. Ground lead (Black)
18. Immobilizer LED (Yellow)
19. Ignition switched live and Instrument panel lighting (White)
20. Battery-powered (Yellow-Red)

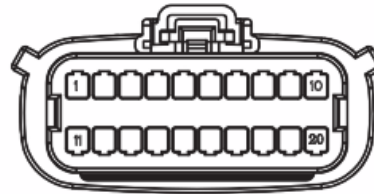
**H.V. COIL.**

1. RoNe (black) - control unit
2. Ne (green) - ground

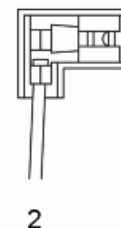
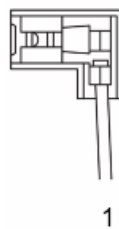

**FUEL LEVEL TRANSMITTER CONNECTOR**

1. Fuel level indicator (White - Green)
2. Ground lead (Black)

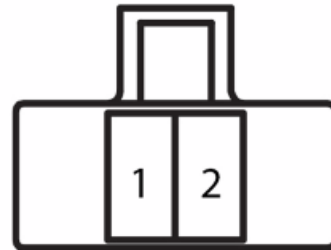

**ABS CONTROL UNIT CONNECTOR**

1. Not connected
2. Ground lead (Black)
3. Speed sensor positive (Light Blue-Red)
4. Speed sensor negative (Ligh Blue-Black)
5. Not connected
6. Not connected
7. Not connected
8. Not connected
9. Line K (Orange-Black)
10. ABS warning light (Blue)
11. Vehicle speed signal (Sky blue)
12. Not connected
13. Battery powered (Red-Green)
14. Ignition switched live (Red-Blue)

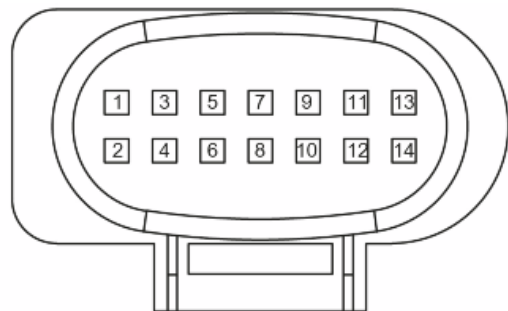

**LICENCE PLATE LIGHT CONNECTOR**

1. Ground lead (Black)
2. Power supply (Yellow-Black)

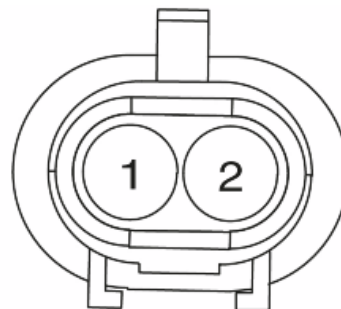

**STOP LIGHT**

1. Ground lead (Black)
2. Power supply (White - Black)

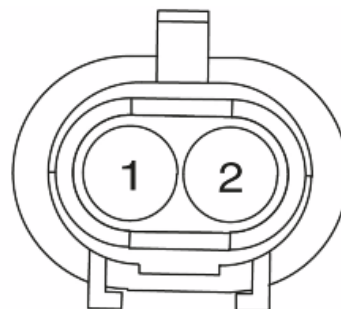

**HORN**

1. Horn button (Grey - Black)

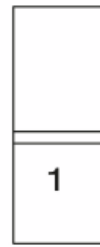

1. Ground lead (Black)

**TURN INDICATORS CONTROL DEVICE**

1. Ignition switched live (White)
2. Turn indicator switch (Blue-Black)

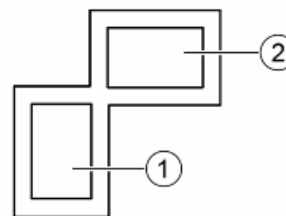
**USB PORT**

1. Ignition switched live (Grey-Red)
2. Ground lead (Black)

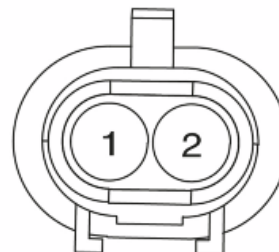
**REAR DAYLIGHT RUNNING LIGHT**

1. Ground lead (Black)
2. Ignition switched live (Yellow-Black)

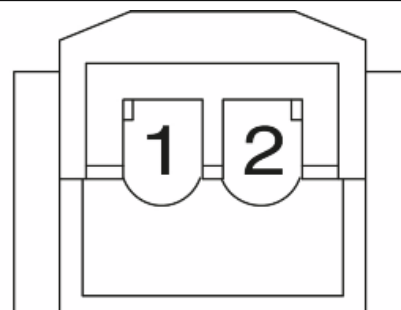

**TPS**

1. Negative from control unit (Black-Green)
2. Control unit positive (Red-Black)
3. Signal (Orange-White)

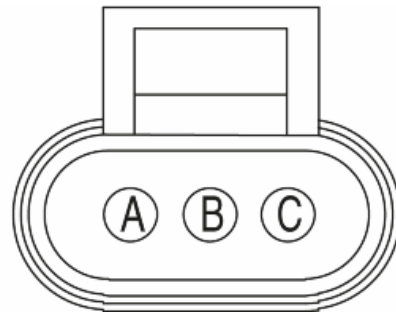

**REAR RIGHT TURN INDICATOR**

1. Ground lead (Black)
2. Power supply (White-Blue)

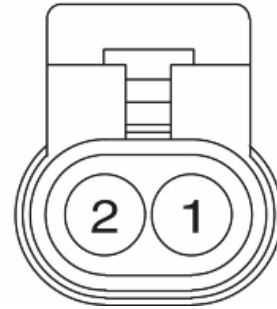

**REAR LEFT TURN INDICATOR**

1. Ground lead (Black)
2. Power supply (Pink)

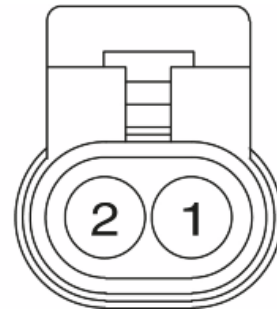

**STARTER RELAY**

- A. Battery positive (Red)
- B. Starter motor (Red)
- C. Negative from the control unit (Green-Yellow)
- D. Ignition button (Purple)

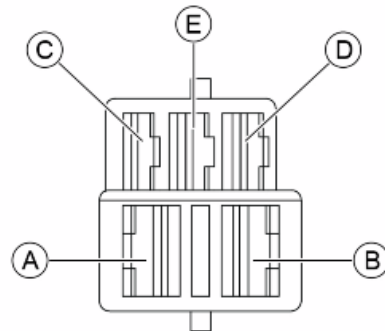

**STAND BUTTON**

1. Start enable (Orange)
2. Negative from control unit (Grey-Green)

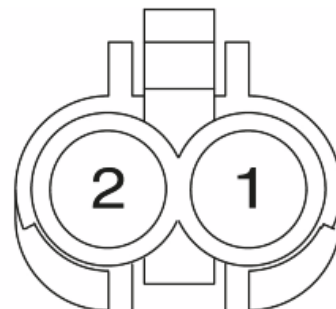

**SADDLE OPENING ACTUATOR**

1. Ground lead (Black)
2. Live supply (Orange-Blue)

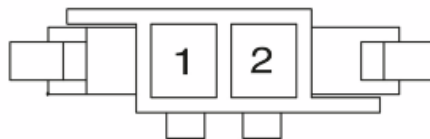
**HEADLIGHT**

1. Low beam light (Brown)
2. High-beam light (Purple)
3. Ground lead (Black)

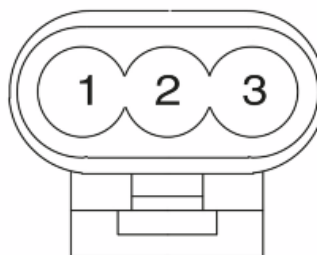
**CONTROLS ON THE HANDLEBAR RIGHT****HAND SIDE**

1. Live (Grey-White)
2. Stop button positive (White)
3. Starter button (Purple)
4. Stop button negative (White-Black)
5. Not connected
6. Not connected
7. MODE button positive (Green)
8. MODE button negative (Black)
9. Light selector switch (Grey)
10. Daylight running light (Yellow-Black)

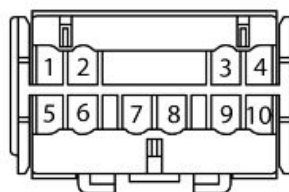
**CONTROLS ON THE HANDLEBAR LEFT HAND****SIDE**

1. High-beam light (Purple)
2. Low beam light (Brown)
3. Horn (Grey - Black)
4. Horn power supply (White)
5. High/low beam light power supply (Grey)
6. High beam light flashing power supply (Grey-Red)
7. RH direction indicator (White-Blue)
8. Turn indicator power (Blue-Black)
9. LH direction indicator (Pink)
10. Not connected

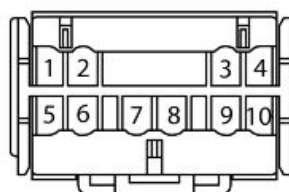

**IGNITION SWITCH**

1. Saddle opening button ignition switched live power supply (Grey-Black)
2. Not connected
3. Power supply from the battery (Yellow-Red)
4. Battery-powered (Red-Black)
5. Secondary fuses ignition switched live (Orange)

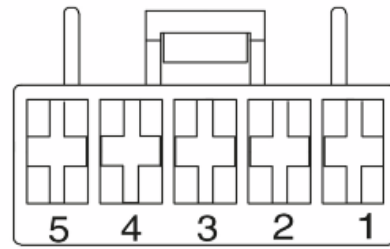

**DAYLIGHT RUNNING LIGHT AND RH FRONT**

**TURN INDICATORS**

1. Parking light (Yellow-Black)
2. Ground lead (Black)
3. Turn indicator (White - Blue)

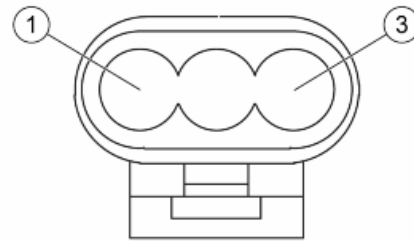

**DAYLIGHT RUNNING LIGHT AND LH FRONT**

**TURN INDICATORS**

1. Parking light (Yellow-Black)
2. Ground lead (Black)
3. Turn indicator (Pink)

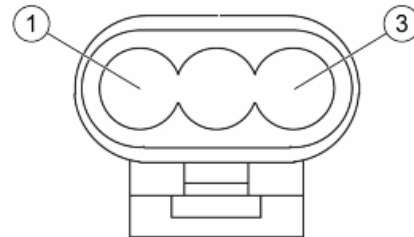

**SADDLE OPENING SWITCH**

1. Ignition switched live (Grey-Black)
2. Saddle opening actuator (Orange-Blue)

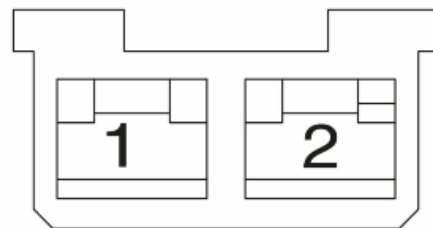

**ABS SENSOR**

1. Negative from ABS control unit (Light blue-Black)
2. Signal (Sky blue-Red)

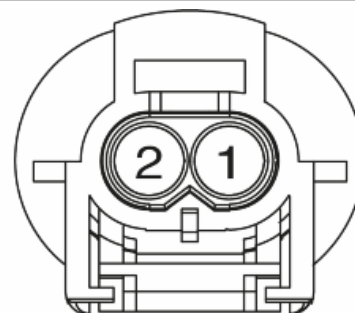



**CANISTER VALVE (IF APPLICABLE)**

1. Negative from the control unit (Green-White)
2. Positive from the control unit (Black - Green)

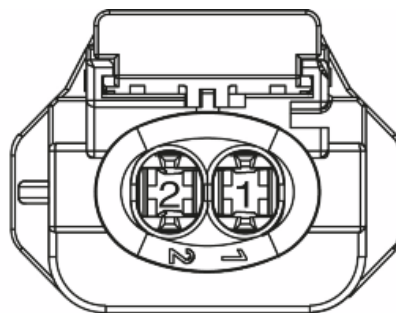
**OBD PORT (CHINA VERSION)**

1. Ignition switched live (Grey-Red)
2. Not connected
3. Ground lead (Black)
4. Battery-powered (Yellow-Red)
5. Not connected
6. Line K (Orange)

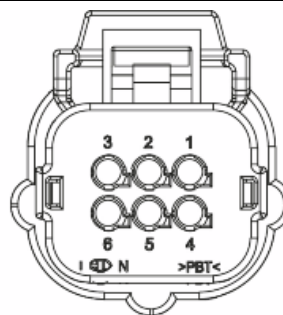
**FOR THE VERSION WITH "TFT" INSTRUMENT PANEL****DIAGNOSTIC CONNECTOR**

1. Not connected
2. Ground lead (Black)
3. Line K

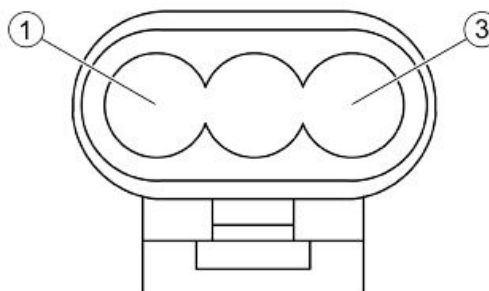
**FLYWHEEL**

- a1. Gi - Voltage regulator
- b1. GrVe - Pickup -
- c1. Gi - Voltage regulator
- a2. RoBi - Engine oil pressure sensor
- b2. Gi - Voltage regulator
- c2. Rs - pickup +

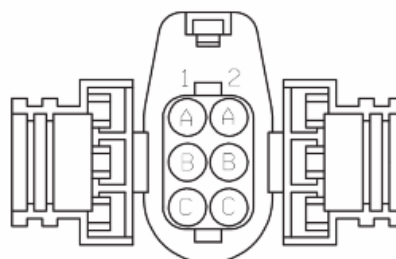

**FUEL PUMP CONNECTOR**

1. Not connected
2. Negative from control unit (Green)
3. Not connected
4. Not connected
5. Power from control unit (Black - Green)

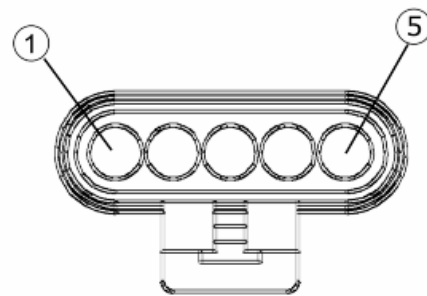
**INJECTION ECU**

1. Ve - fuel pump
2. MaBi - injection warning light
3. AzRs - lambda probe heater
4. Gi - immobilizer LED
5. RsBi - + battery
6. RsGi - injector ground
7. GrVe - sensor ground
8. RoNe - + H.V. coil
9. NeVe - + loads
10. ArNe - K Line
11. VeGi - ignition activation / VeBi - canister valve  
(if applicable)
12. Rs - pickup +
13. VeBL - Lambda +
14. ArBi - TPS sensor
15. Ar - side stand switch
16. AzVe - engine temperature sensor
17. BiNe - idle regulator valve
18. RsNe - +5V sensors
19. Ne - ground
20. RsBL - + key-on power

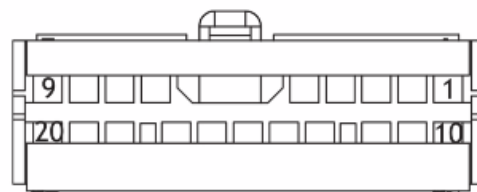

**ENGINE TEMPERATURE SENSOR CONNECTOR**

1. Electronic control unit (Sky blue - Green)
2. Ground lead (Grey-Green)

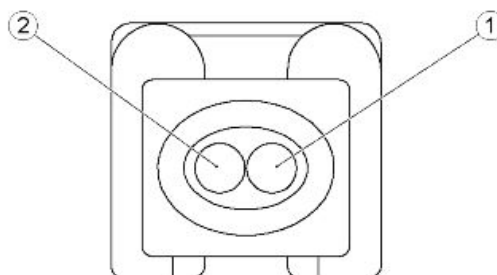
**INJECTOR CONNECTOR**

1. Negative from control unit (Red-Yellow)
2. Power from control unit (Black - Green)

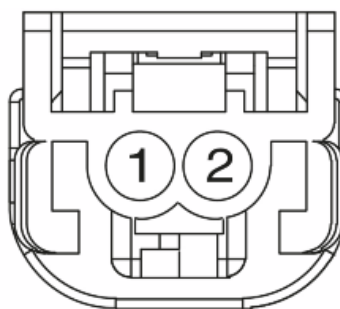
**LAMBDA PROBE CONNECTOR**

1. Lambda signal positive (Green-Blue)
2. Lambda signal negative (Grey-Green)
3. Heater ECU negative (Light blue-Red)
4. Heater supply from ECU (Black-Green)

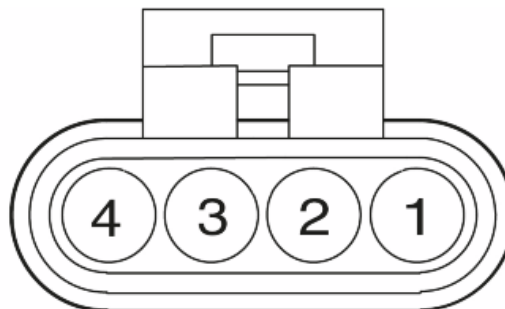
**VOLTAGE REGULATOR**

1. RsNe - positive
2. not connected
3. Ne - ground
4. Gi - flywheel
5. Gi - flywheel
6. Gi - flywheel

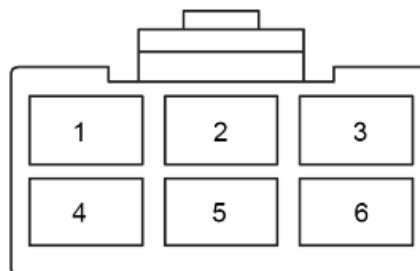

**INSTRUMENT PANEL**

1. Not connected
2. Not connected
3. Not connected
4. Fuel level indicator (BiVe)
5. Air temperature signal (GiBL)
6. MIL warning light (MaBi)
7. Not connected
8. Not connected
9. Battery power supply (GiRs)
10. Not connected
11. Not connected
12. MODE button (central pressing) (MaNe)
13. Oil pressure warning light (RoNe)
14. High beam warning light (Vi)
15. ABS warning light (BL)
16. Ignition switched live (Bi)
17. Not connected
18. Vehicle speed signal (Sky blue)
19. Right turn indicators light (BiBL)
20. Left turn indicators light (Ro)
21. Immobilizer indicator light (Ro)
22. MODE button (right side pressing) (AzNe)
23. MODE button (left side pressing) (ViNe)
24. Ground (Ne)
25. Sensor ground (Ne)
26. Not connected
27. Not connected
28. Not connected
29. Not connected
30. Not connected
31. Not connected
32. CAN L line (RoBi)
33. CAN H LINE (BiGr)
34. Not connected

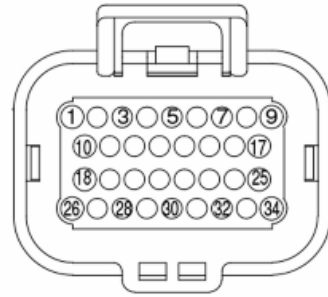

**H.V. COIL.**

1. RoNe (black) - control unit
2. Ne (green) - ground



1

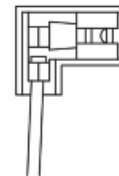

2

**FUEL LEVEL TRANSMITTER CONNECTOR**

1. Ground (Ne)
2. Control unit (RoNe)

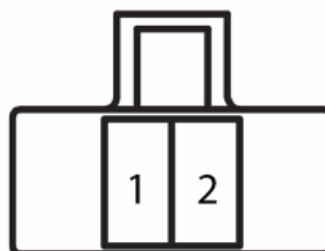
**ABS CONTROL UNIT CONNECTOR**

1. Not connected
2. Ground lead (Black)
3. Speed sensor positive (Light Blue-Red)
4. Speed sensor negative (Ligh Blue-Black)
5. Not connected
6. Not connected
7. Not connected
8. Not connected
9. Line K (Orange-Black)
10. ABS warning light (Blue)
11. Vehicle speed signal (Sky blue)
12. Not connected
13. Battery powered (Red-Green)
14. Ignition switched live (Red-Blue)

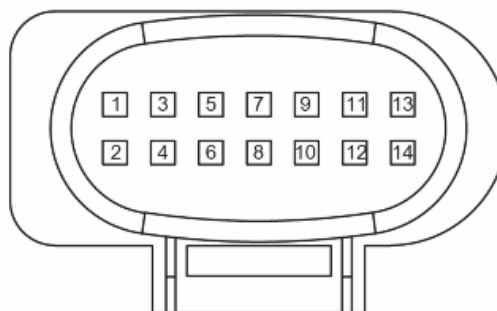

**LICENCE PLATE LIGHT CONNECTOR**

1. Ground lead (Black)
2. Power supply (Yellow-Black)

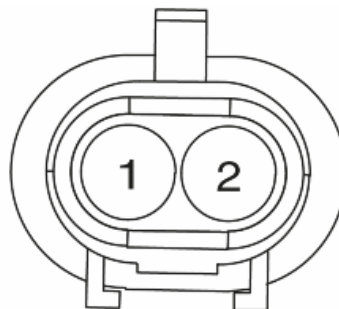

**STOP LIGHT**

1. Ground lead (Black)
2. Power supply (White - Black)

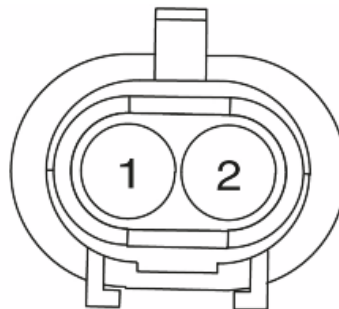

**HORN**

1. Horn button (Grey - Black)

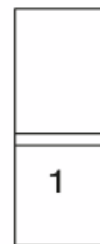

1. Ground lead (Black)



**TURN INDICATORS CONTROL DEVICE**

1. Ignition switched live (White)
2. Turn indicator switch (Blue-Black)

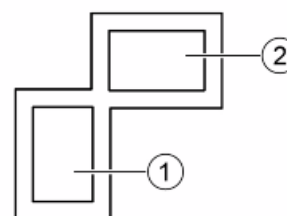

**USB PORT**

1. Ignition switched live (Grey-Red)
2. Ground lead (Black)

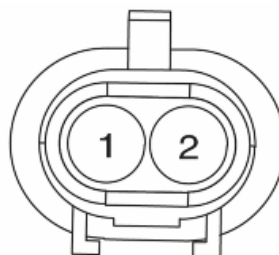
**REAR DAYLIGHT RUNNING LIGHT**

1. Ground lead (Black)
2. Ignition switched live (Yellow-Black)

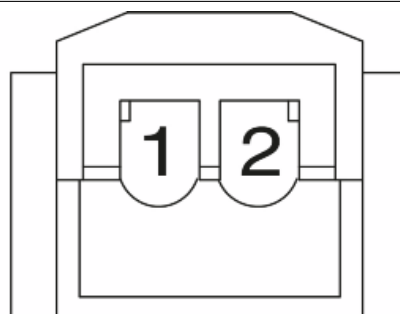
**TPS**

- A** Ground (GrVe)  
**B** Positive from the control unit (Red-Black)  
**C** Signal (Orange-White)

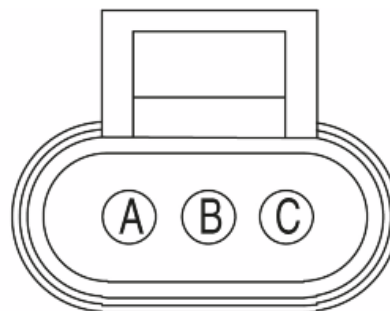
**REAR RIGHT TURN INDICATOR**

1. Ground lead (Black)
2. Power supply (White-Blue)

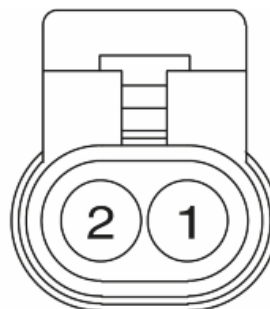
**REAR LEFT TURN INDICATOR**

1. Ground lead (Black)
2. Power supply (Pink)

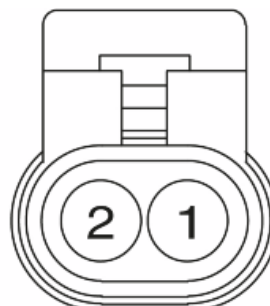

**STARTER RELAY**

- A. Battery positive (Red)
- B. Starter motor (Red)
- C. Negative from the control unit (Green-Yellow)
- D. Ignition button (Purple)

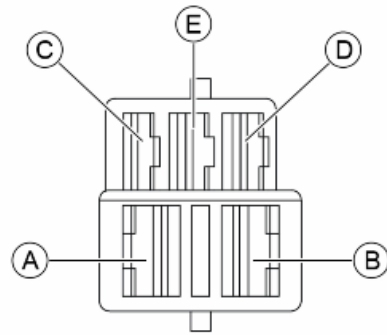

**STAND BUTTON**

- 1. Start-up enabling (Ar)
- 2. Negative from the control unit (ArNe)

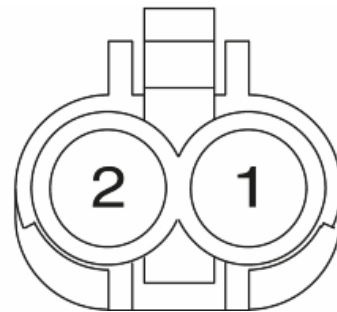

**SADDLE OPENING ACTUATOR**

- 1. Ground lead (Black)
- 2. Live supply (Orange-Blue)

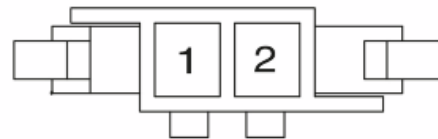

**HEADLIGHT**

- 1. Low beam light (Brown)
- 2. High-beam light (Purple)
- 3. Ground lead (Black)

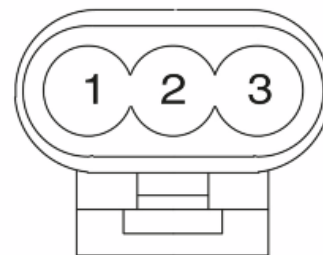

**CONTROLS ON THE RIGHT SIDE OF THE HANDLEBAR**

- 1. Ignition switched live (Bi)
- 2. Stop button positive (BiNe)
- 3. Engine stop button positive (ArNe)
- 4. Engine stop button negative (GrVe)
- 5. Starter button negative (Vi)
- 6. Starter button positive (BiNe)
- 7. Ground (Ne)
- 8. MODE button (right side pressing) (AzNe)

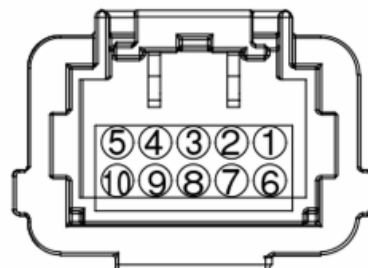



9. MODE button (left side pressing) (ViNe)

10. MODE button (central pressing) (MaNe)

---

### CONTROLS ON THE LEFT SIDE OF THE HAN- DLEBAR

1. High-beam light (Purple)
2. Low beam light (Brown)
3. Horn (Grey - Black)
4. Horn power supply (White)
5. High beam/low beam light power supply (Grey-Black)
6. High beam flashing power supply (Grey-Red)
7. RH direction indicator (White-Blue)
8. Turn indicator power (Blue-Black)
9. LH direction indicator (Pink)
10. Ignition switched live (White-Black)

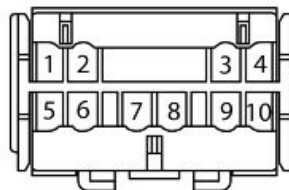

---

### IGNITION SWITCH

1. Saddle opening button ignition switched live power supply (Grey-Black)
2. Not connected
3. Power supply from the battery (Yellow-Red)
4. Battery-powered (Red-Black)
5. Secondary fuses ignition switched live (Orange)

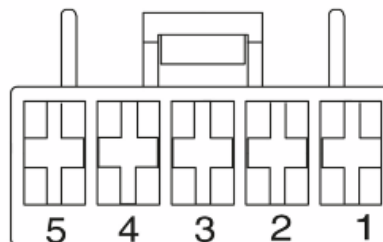

---

### MAIN FUSE

1. Battery power supply input for fuse F01 (Rs)
1. Battery power supply output for fuse F02 (Rs)
2. Battery power supply output for fuse F01 (RsNe)

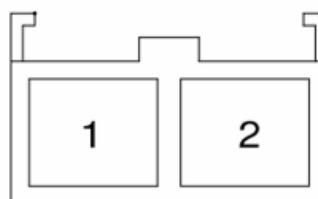

**ABS CONTROL UNIT FUSE**

1. Battery power supply input for fuse F02 (Rs)
2. Battery power supply for the ABS control unit (RsVe)

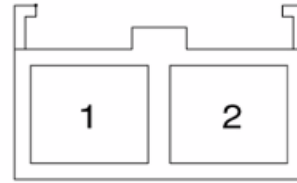

**DAYLIGHT RUNNING LIGHT AND RH FRONT**

**TURN INDICATORS**

1. Parking light (Yellow-Black)
2. Ground lead (Black)
3. Turn indicator (White - Blue)

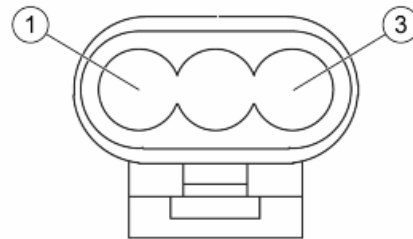

**DAYLIGHT RUNNING LIGHT AND LH FRONT**

**TURN INDICATORS**

1. Parking light (Yellow-Black)
2. Ground lead (Black)
3. Turn indicator (Pink)

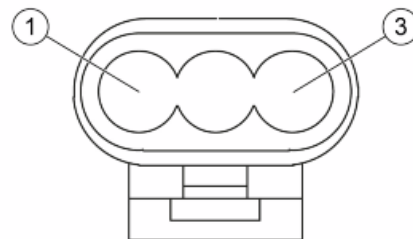

**PMP2**

1. Ignition switched live (Bi)
2. Ground (Ne)
3. CAN H LINE (BiGr)
4. CAN L line (RoBi)
5. K line (ArNe)
6. Fuel level indicator (BiVe)
7. RH turn indicator signal (BiBL)
8. LH turn indicator signal (Ro)

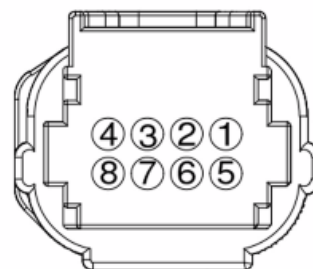

**OBD PORT (CHINA VERSION)**

1. Ignition switched live (GrRs)
2. CAN H LINE (BiGr)
3. Ground (Ne)
4. Battery power supply (GiRs)
5. CAN L line (RoBi)
6. K line (Orange)

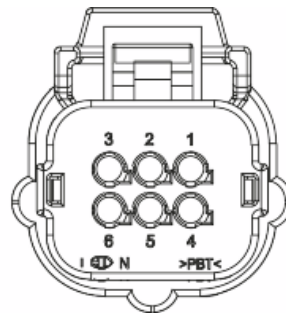
**SADDLE OPENING SWITCH**

1. Ignition switched live (Grey-Black)
2. Saddle opening actuator (Orange-Blue)

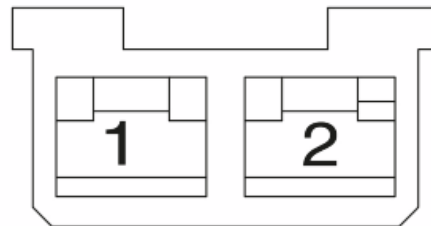
**AIR TEMPERATURE SENSOR**

1. Ground (Ne)
2. Signal for the instrument panel (GiBL)

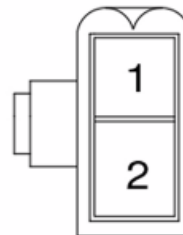
**ABS SENSOR**

1. Negative from ABS control unit (Light blue-Black)
2. Signal (Sky blue-Red)

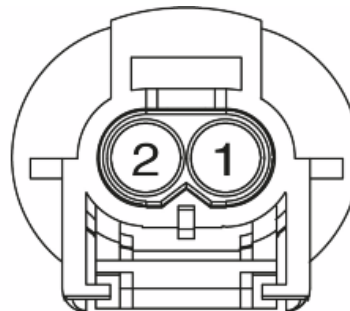
**TFT**

1. CAN H LINE (BiGr)
2. CAN L line (RoBi)
3. Ignition switched live (Bi)
4. Ground (Ne)
5. Battery power supply (GiRs)

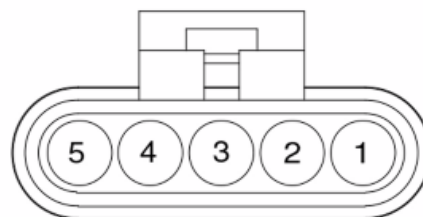

---

**CANISTER VALVE (IF APPLICABLE)**

1. Negative from the control unit (Green-White)
2. Positive from the control unit (Black - Green)

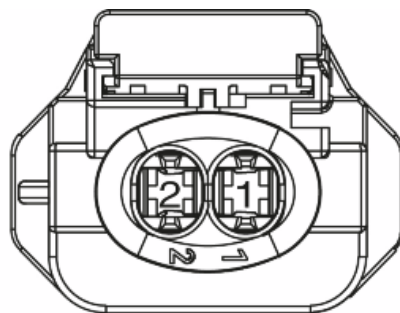

---

**BATTERY POSITIVE**

1. Battery power supply for fuse F01 (Rs)
1. Battery power supply for fuse F02 (Rs)



---

**BATTERY NEGATIVE**

1. Ground for battery (Ne)



---

**CHASSIS-ENGINE GROUND**

1. Ground (Ne)



**FRAME GROUND**

1. Ground (Ne)

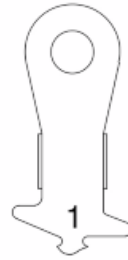
**STARTER MOTOR NEGATIVE**

1. Ground (Ne)

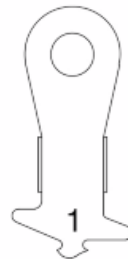
**STARTER MOTOR POSITIVE**

1. Power supply from the starter relay contact (Rs)

**IDLE VALVE**

1. Negative from the control unit (BiNe)
2. Positive from the control unit (NeVe)

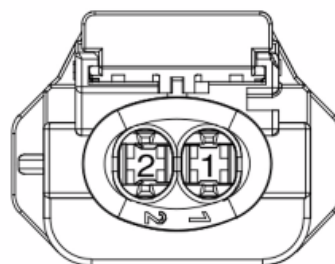

**DIODE (CHINA VERSION)**

K Negative for the ignition coil (Ve)

A Negative for the fuel pump (VeGi)



**RESISTANCE**

1. CAN L line (RoBi)
2. CAN H LINE (BiGr)



**Duplication of keys / remote controls**

**RADIO CONTROL WITH 5 PIN CONNECTOR**

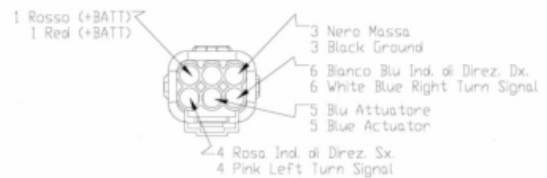

To program the new radio controls, do the following:

1. disconnect the battery of the vehicle;
2. reconnect the battery of the vehicle;
3. within 5 seconds of reconnecting the battery, simultaneously press buttons "1" and "3" on the remote control twice. the «Bike Finder» device will confirm the process with an optical signal by the quick flashing of the turn indicator;

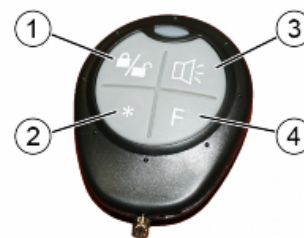

4. the programming of the new radio control generates the end of the procedure and the system is ready for use.

If it is necessary to erase a radio control from the memory of the device, it will be necessary to repeat the programming 4 times even with the same remote control, in order to recover the 4 provided memories.

#### CAUTION



**TO STORE THE OTHER REMOTE CONTROLS TO MEMORY (4 MAXIMUM) YOU NEED TO REPEAT THE WHOLE PROCEDURE AGAIN. FAILURE TO CARRY OUT THESE OPERATIONS WITHIN THE INDICATED TIMES WILL RESULT IN THE REMOTE-CONTROL UNIT KEY PROGRAMMING PROCEDURE BEING ABANDONED AUTOMATICALLY. STORING A FIFTH REMOTE CONTROL MAY LEAD TO CANCELLATION OF THE FIRST ONE.**

#### WARNING



**DO NOT KEEP THE REMOTE CONTROL IN PLACES WITH TEMPERATURES EXCEEDING 60° C: THE BATTERY WILL RUN DOWN TOO QUICKLY.**

#### CAUTION



**TO AVOID BATTERY DISCHARGE, THE SADDLE OPENING REMOTE CONTROL RADIO RECEIVER DEACTIVATES 3 MINUTES AFTER THE LAST RECEIPT. TO RESTORE FUNCTIONS SIMPLY PRESS THE ACTIVATION BUTTON ON THE REMOTE CONTROL FOR ABOUT 3 SECONDS, AS DESCRIBED ABOVE.**

#### RADIO CONTROL WITH 6 PIN CONNECTOR

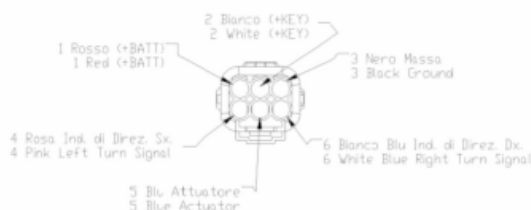

To program the new radio controls, do the following:

1. switch from "OFF" to "ON" 5 times within 5 seconds;
2. within 5 seconds from the last key switch to "OFF", press the "1" and "3" on the remote control twice at the same time. the «Bike Finder» device will confirm the process with an optical signal by the quick flashing of the turn indicator;
3. the programming of the new radio control generates the end of the procedure and the system is ready for use.



If it is necessary to erase a radio control from the memory of the device, it will be necessary to repeat the programming 4 times even with the same remote control, in order to recover the 4 provided memories.

#### CAUTION



TO STORE THE OTHER REMOTE CONTROLS TO MEMORY (4 MAXIMUM) YOU NEED TO REPEAT THE WHOLE PROCEDURE AGAIN. FAILURE TO CARRY OUT THESE OPERATIONS WITHIN THE INDICATED TIMES WILL RESULT IN THE REMOTE-CONTROL UNIT KEY PROGRAMMING PROCEDURE BEING ABANDONED AUTOMATICALLY. STORING A FIFTH REMOTE CONTROL MAY LEAD TO CANCELLATION OF THE FIRST ONE.

#### WARNING



DO NOT KEEP THE REMOTE CONTROL IN PLACES WITH TEMPERATURES EXCEEDING 60° C: THE BATTERY WILL RUN DOWN TOO QUICKLY.

#### CAUTION



TO AVOID BATTERY DISCHARGE, THE SADDLE OPENING REMOTE CONTROL RADIO RECEIVER DEACTIVATES 3 MINUTES AFTER THE LAST RECEIPT. TO RESTORE FUNCTIONS SIMPLY PRESS THE ACTIVATION BUTTON ON THE REMOTE CONTROL FOR ABOUT 3 SECONDS, AS DESCRIBED ABOVE.

## Diagnostic instrument

### BATTERY



**ELECTRICAL ERRORS****Low power supply P0562**Error cause

The battery voltage is below the minimum threshold.

Troubleshooting

Check the battery, the voltage regulator, the correct function of the alternator (flywheel) and the relative connectors.

**High power supply P0563**Error cause

The battery voltage is over the maximum threshold.

Troubleshooting

Check the battery, the voltage regulator, the correct function of the alternator (flywheel) and the relative connectors.

---

**IMMOBILIZER ANTENNA****Function**

Detects the transponder code in the key and sends it to the engine control unit.

**ERRORS**

**Immobilizer P0513** - unknown transponder.

Error cause

The key has the working transponder, but it is not within the recognised ones.

Troubleshooting

Store the new key.

**Immobilizer P1514** - not working antenna or key without transponder.

Error cause

Antenna electrical fault or the key has no transponder or the transponder is damaged.

Troubleshooting

Replace the key and store it if necessary. If the error persists, check the electrical characteristics and the continuity of the antenna circuit:

- Disconnect the antenna connector and check the correct resistance value at the ends.
- Check wiring continuity between the antenna and the engine control unit and restore if necessary.

**Electric characteristic****Resistance at 20°C**

7.66 ± 5% Ω

---

**HV COIL****Function**

Allows generation of the electrical discharge on the spark plug, with an increase of voltage.

**Pin-out:**

1. Control unit power
2. Ground lead

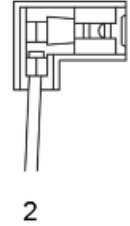
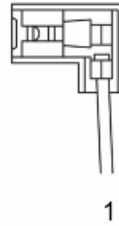
**ELECTRICAL ERRORS**

**H.V. coil P0351** - open circuit.

Error cause

Open circuit: broken circuit.

Troubleshooting

Open circuit:

- Carry out the check procedure of the coil and control unit connectors.
  - Check the ground and battery-powered insulation of coil PIN 1.
  - Verify continuity of the wiring harness between the coil and control unit: Coil PIN 1 - control unit PIN 8.
8. If there is no continuity, restore the wiring harness.
- Check the ground connection of coil PIN 2. Repair the wiring harness if necessary.
  - If the above tests provided a positive result, the coil should be replaced.

**INJECTOR****Function**

Provide the correct amount of fuel at the correct time.

**Operation / Operating principle**

Injector coil is excited for the petrol passage to open.

**Pin-out:**

1. Negative from control unit (injector activation)
2. Positive from control unit

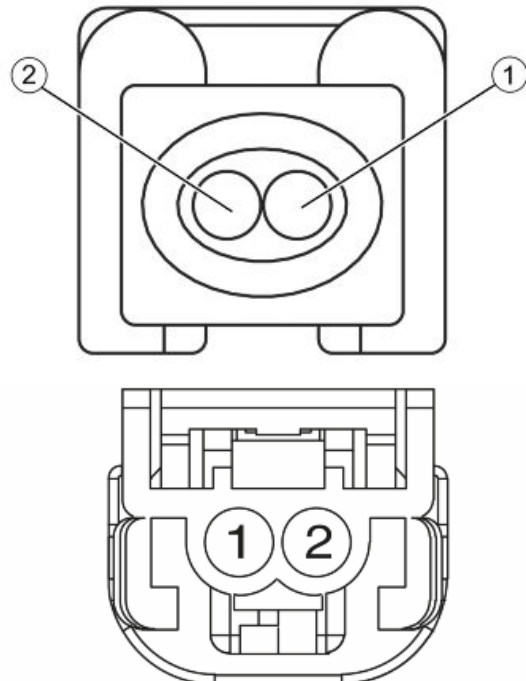
**ELECTRICAL ERRORS**

**Low injector voltage P0261** - open circuit or short-circuit to negative.

Error cause

Open circuit or Short-circuit to negative: interruption of the circuit or null voltage at PIN 1 of the injector connector.

Troubleshooting

Open circuit:

- Perform the check of the injector and control unit connectors.
- Check the continuity of the wiring harness between the control unit connector and injector connector: Control unit PIN 6 - injector PIN 1 and control unit PIN 9 - injector PIN 2. If there is no continuity, restore the wiring harness.

Short-circuit to negative:

- Disconnect the control unit connector and the injector connector.
- Check the injector connector PIN 1 ground insulation (corresponding to control unit connector PIN 6). If there is no insulation, restore the wiring harness.
- With the injector connector disconnected and the control unit connector connected, turn ignition switch to ON and activate the component using the diagnostic tool.
- Check if there is intermittent voltage (4 ms every second for 5 seconds) at the ends of the injector connector.
- If there is no voltage, check the continuity of the wiring harness between control unit PIN 9 and injector PIN 2 and restore it if necessary.
- If the above tests provided a positive result, the injector should be replaced.

**High injector voltage P0262** - short-circuit to positive.

Error cause

Short-circuit to positive: excessive voltage to PIN 6 of the control unit connector.

Troubleshooting

Short-circuit to positive:

- Disconnect the control unit connector and the injector connector.
  - Verify that there is no short to battery positive on injector connector PIN 1 (corresponding to control unit connector PIN 6); if there is a short circuit, restore the wiring harness.
  - With the injector connector disconnected and the control unit connector connected, turn ignition switch to ON and activate the component using the diagnostic tool.
  - Check if there is intermittent voltage (4 ms every second for 5 seconds) at the ends of the injector connector.
  - If there is no voltage, check the continuity of the wiring harness between control unit PIN 9 and injector PIN 2 and restore it if necessary.
  - If the above tests provided a positive result, the injector should be replaced.
-